

1. VACUUM

- Remove the cap, and connect the gauge manifold and the vacuum pump to the charging valve by the service hoses.
- Vacuum the indoor unit and the connecting pipes until the pressure in them lowers to below 1.5 mmHg.
- Disconnect the service hoses and fit the cap to the charging valve (Tightening torque : 70 to 90 kgf-cm).
- Remove the blank caps, and fully open the spindles of the 2-way and 3-way valves with a hexagon wrench (Torque : 2-way valve: 70 to 90 kgf-cm, 3-way valve: 100 to 120 kgf-cm).
- Tighten the blank caps of the 2-way valve and 3-way valve to the specified torque (200 to 250 kgf-cm).

Fig. 25

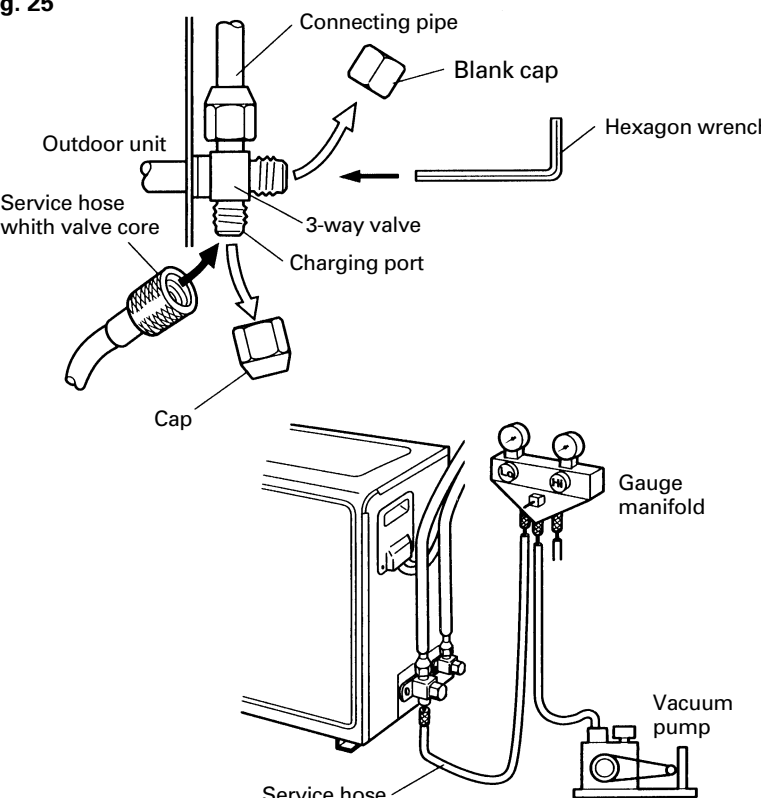

2. ADDITIONAL CHARGE

Refrigerant suitable for a piping length of 7.5 m is charged in the outdoor unit at the factory.
When the piping is longer than 7.5 m, additional charging is necessary. For the additional amount, see the table below.

Table 4

Pipe length	16 ft (7.5 m)	33 ft (10 m)	49 ft (15 m)	66 ft (20 m)
Additional refrigerant	None	1.8 oz (50 g)	5.3 oz (150 g)	8.8 oz (250 g)

Between 7.5 m and 20 m, when using a connection pipe other than that in the table, charge additional refrigerant with 0.71 oz (20 g) / 3.3 ft (1 m) (Cooling model) as the criteria.

6

GAS LEAKAGE INSPECTION

CAUTION

After connecting the piping, check the joints for gas leakage with gas leak detector.

7

OUTDOOR UNIT WIRING

WARNING

- Before starting work, check that power is not being supplied to indoor unit and the outdoor unit.
- Match the terminal block numbers and connection cord colors with those of the indoor unit side. Erroneous wiring may cause burning of the electric parts.
- Connect the connection cords firmly to the terminal block. Imperfect installation may cause a fire.
- Always fasten the outside covering of the connection cord with cord clamps. (If the insulator is clamped, electric leakage may occur.)
- Always connect the ground wire.

CAUTION

- The power cord is not supplied with the outdoor unit. Use 2.5 mm² to 3.5 mm² H07RN-F or equivalent as the connection cord.
- Use VW-1, 12 mm diameter, 0.5 to 1.0 mm thick, PVC tube as the insulation tube.

- Remove the outdoor unit terminal cover.
- Process the end of the connection cords to the dimensions shown in Fig. 27 and bend the end of each cord as shown in Fig. 26.
- Connect the end of the connection cord fully into the terminal block and fasten with the screws.
- Fasten the sheath with a cord clamp.
- Install the terminal cover.

Fig. 26 Stripped length

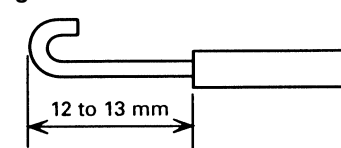
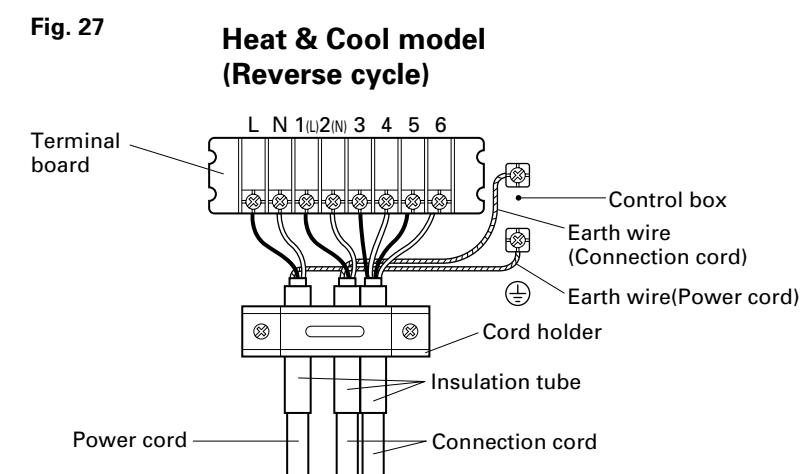
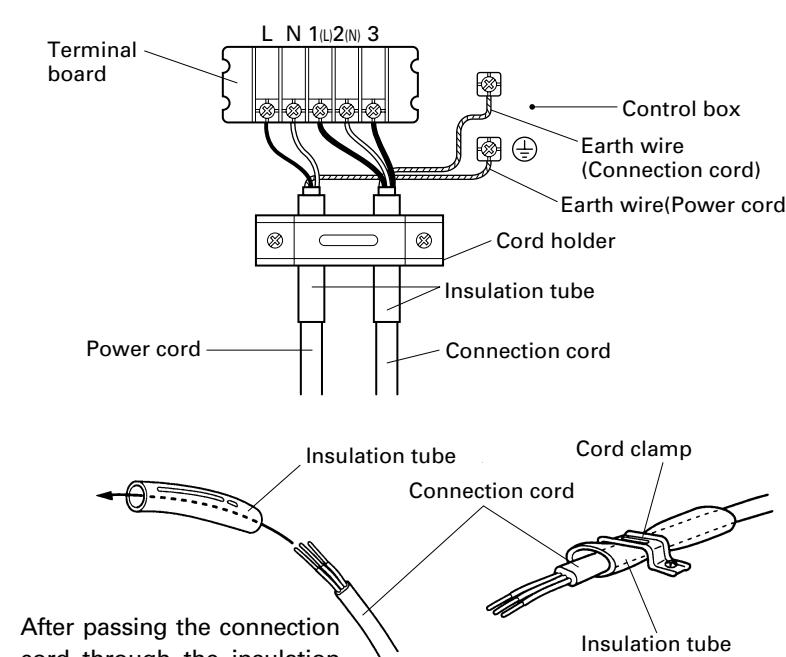

Fig. 27



Cooling model



1. CONNECTION DIAGRAM

Fig. 28

Heat & Cool model (Reverse cycle)

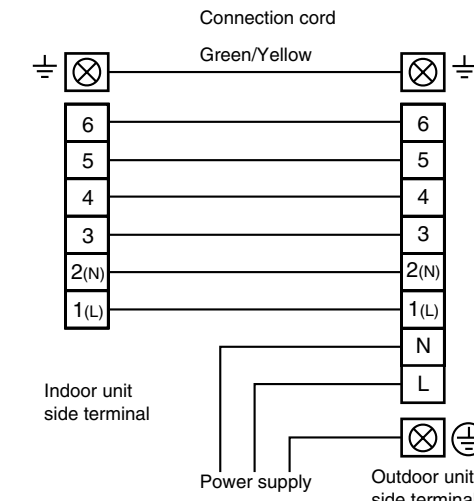

Cooling model

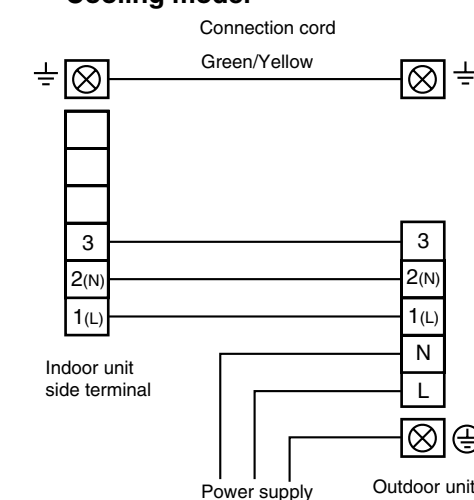

8

FINISHING

- Insulate between pipes.
 - For rear, right, and bottom piping, overlap the connection pipe heat insulation and indoor unit pipe heat insulation and bind them with vinyl tape so that there is no gap.
 - For left and left rear piping, butt the connection pipe heat insulation and indoor unit pipe heat insulation together and bind them with vinyl tape so that there is no gap.

Fig. 29

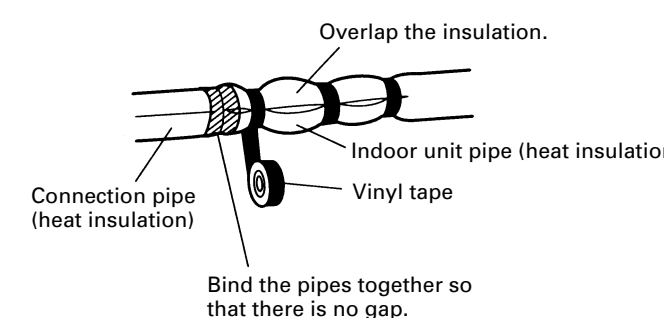

- For left and left rear piping, wrap the area which accommodates the rear piping housing section with cloth tape.

Fig. 30

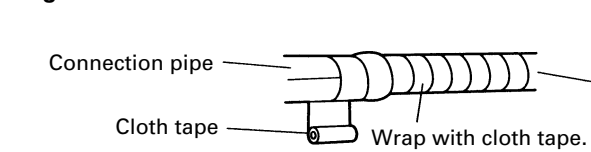

- For left and left rear piping, bind the connection cord to the top of the pipe with vinyl tape.

Fig. 31

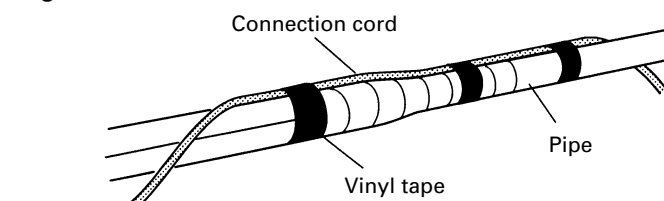

- For left and left rear piping, bundle the piping and drain hose together by wrapping them with cloth tape over the range within which they fit into the rear piping housing section.

Fig. 32

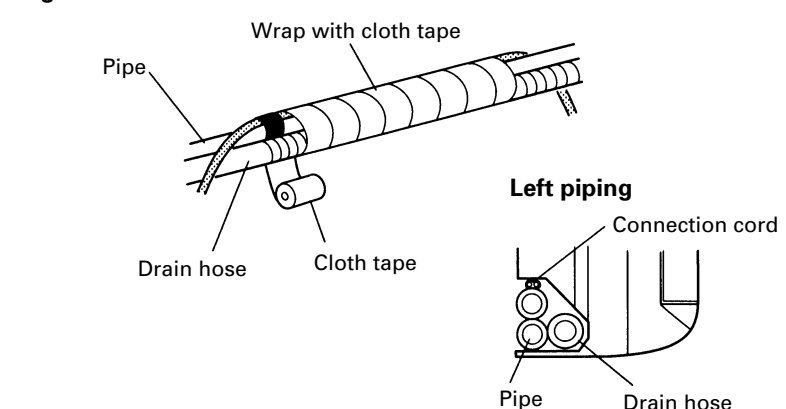

10

TEST RUNNING

- Press the remote control unit test run button while the air conditioner is running.
- At the end of test running, press the remote control unit start-stop button. (Fig. 38)

Fig. 38

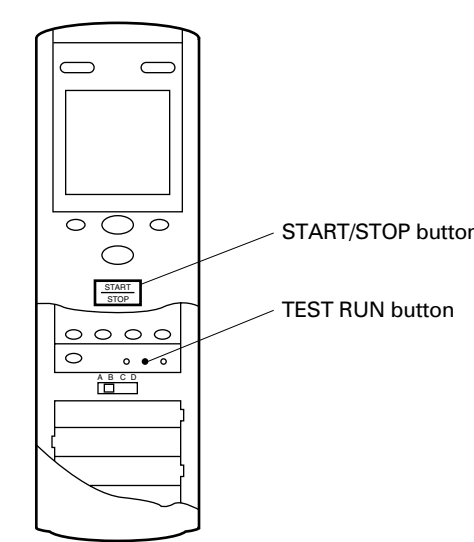

Operation can be checked by lighting and flashing of the display section OPERATION and TIMER lamps.
Perform judgement in accordance with the following.

- Test running
 - When the air conditioner is run by pressing the remote control unit test run button, the OPERATION and TIMER lamps flash slowly at the same time.
- Error
 - The OPERATION and TIMER lamps operate as follows (Table 5) according to the error contents.

Table 5

Error display	Error contents
	Room temperature thermostat abnormal temperature detected
	Piping thermostat abnormal temperature detected

CHECK ITEMS

(1) INDOOR UNIT

- Is operation of each button on the remote control unit normal?
- Does each lamp light normally?
- Do not air flow direction louvers operate normally?
- Is the drain normal?
- Is there any abnormal noise and vibration during operation?

(2) OUTDOOR UNIT

- Is there any abnormal noise and vibration during operation?
 - Will noise, wind, or drain water from the unit disturb the neighbors?
 - Is there any gas leakage?
- Do not operate the air conditioner in the test running state for a long time.
 - For the operation method, refer to the operating manual and perform operation check.

11

CUSTOMER GUIDANCE

Explain the following to the customer in accordance with the operating manual:

- Starting and stopping method, operation switching, temperature adjustment, timer, air flow switching, and other remote control unit operations.
- Air filter removal and cleaning, and how to use the air louvers.
- Give the operating and installation manuals to the customer.

12

FRONT PANEL REMOVAL

CAUTION

Install the front panel and intake grille securely. If installation is imperfect, the front panel or intake grille may fall off and cause injury.

1. INTAKE GRILLE REMOVAL

- Open the intake grille.
- Open the intake grille and lift the intake grille upward until the hook at the top of the intake grille is unhooked.

Fig. 39

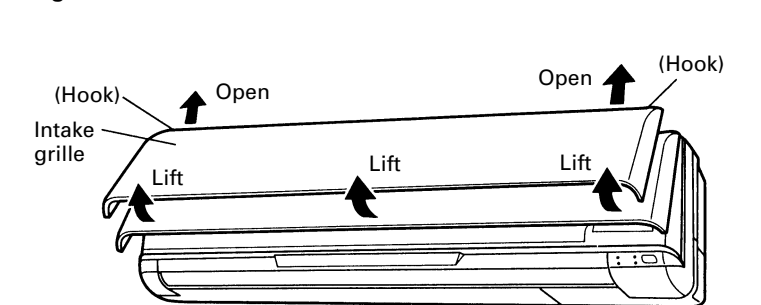

2. FRONT PANEL REMOVAL

- Remove the four tapping screws.
- Remove the front panel by lifting the bottom of the front panel upward.

Fig. 40

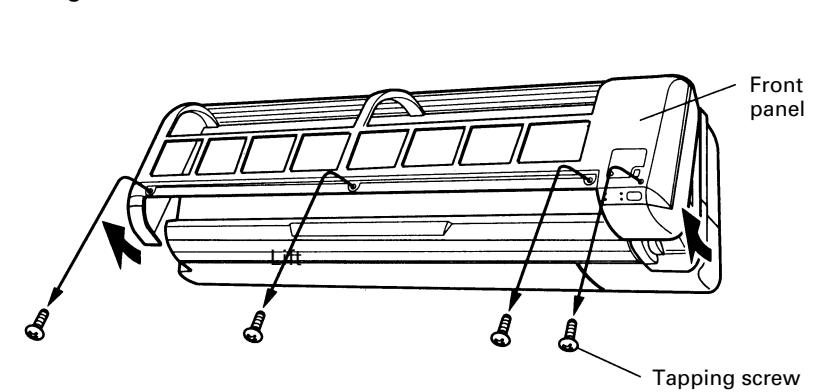

3. FRONT PANEL INSTALLATION

- Hook the top hole of the front panel to the hook of the base.
- Fasten the front panel with the screw.

Fig. 41

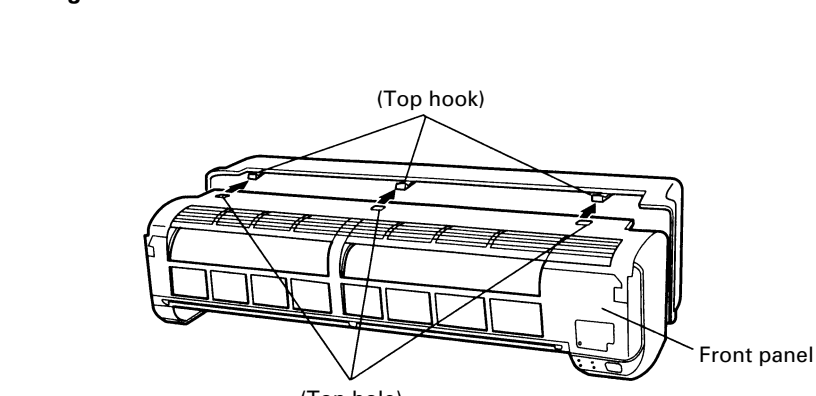

Be sure that the top hole of the front panel is hooked securely to the hook of the base.

13

REMOTE CONTROL UNIT INSTALLATION

CAUTION

- Check that the indoor unit correctly receives the signal from the remote control unit, then install the remote control unit holder.
- Select the remote control unit holder selection site by paying careful attention to the following:
 - Avoid places in direct sunlight.
 - Select a place that will not be affected by the heat from a stove, etc.

1. REMOTE CONTROL UNIT HOLDER INSTALLATION

- Install the remote control unit so that the front is facing the photocell. (Fig. 42)

Fig. 42

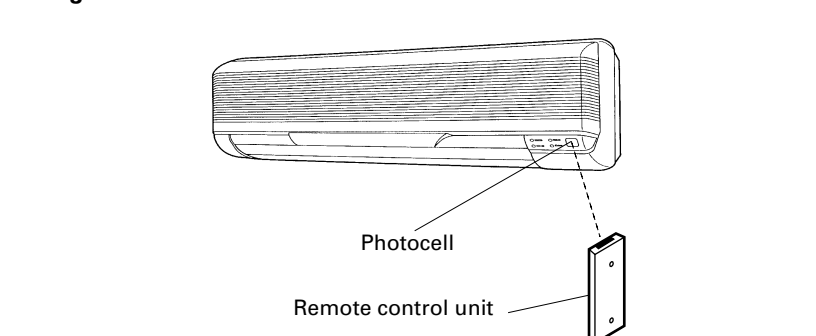

- Install the remote control unit with a distance of 7 m between the remote control unit and the photocell as the criteria. However, when installing the remote control unit, check that it operates positively.
- Install the remote control unit holder to a wall, pillar, etc. with the tapping screw (Fig. 43).

Fig. 43

For use as Handy Type

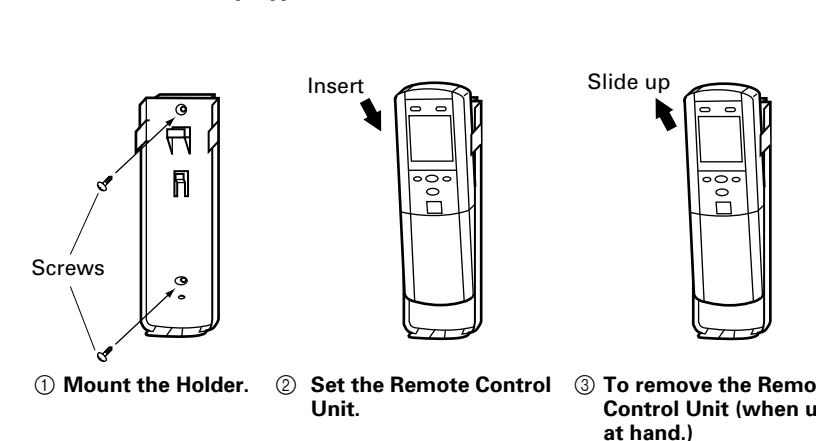

For use as Wall Fixing Type

