

SPLIT TYPE ROOM AIR CONDITIONER INSTALLATION INSTRUCTION SHEET

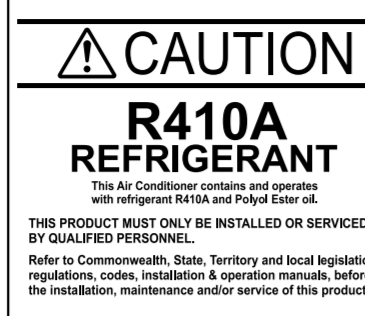

(PART NO. 9373856023)

For authorized service personnel only.

This installation instruction sheet describes how to install the outdoor unit only. To install the indoor unit, refer to the installation instruction sheet included with the indoor unit.

DANGER	This mark indicates procedures which, if improperly performed, are most likely to result in the death or serious injury to the user or service personnel.
WARNING	This mark indicates procedures which, if improperly performed, might lead to the death or serious injury of the user.
CAUTION	This mark indicates procedures which, if improperly performed, might possibly result in personal harm to the user, or damage to property.

This air conditioner uses new refrigerant HFC (R410A).

The basic installation work procedures are the same as conventional refrigerant models. However, pay careful attention to the following points:

- Since the working pressure is 1.6 times higher than that of conventional refrigerant models, some of the piping and installation and service tools are special. (See the table below.) Especially, when replacing a conventional refrigerant model with a new refrigerant R410A model, always replace the conventional piping and flare nuts with the R410A piping and flare nuts.
- Models that use refrigerant R410A have a different charging port thread diameter to prevent erroneous charging with conventional refrigerant and for safety. Therefore, check beforehand. [The charging port thread diameter for R410A is 1/2 UNF 20 threads per inch.]
- Be more careful that foreign matter (oil, water, etc.) does not enter the piping than with refrigerant models. Also, when storing the piping, securely seal the openings by pinching, taping, etc.
- When charging the refrigerant, take into account the slight change in the composition of the gas and liquid phases, and always charge from the liquid phase side whose composition is stable.

Special tools for R410A

Tool name	Contents of change
Gauge manifold	Pressure is high and cannot be measured with a conventional gauge. To prevent erroneous mixing of other refrigerants, the diameter of each port has been changed. It is recommended the gauge with seals -0.1 to 5.3 MPa (-76 cmHg to 53 kgf/cm ²) for high pressure. -0.1 to 3.8 MPa (-76 cmHg to 38 kgf/cm ²) for low pressure.
Charging hose	To increase pressure resistance, the hose material and base size were changed.
Vacuum pump	A conventional vacuum pump can be used by installing a vacuum pump adapter.
Gas leakage detector	Special gas leakage detector for HFC refrigerant R410A.

Copper pipes

It is necessary to use seamless copper pipes and it is desirable that the amount of residual oil is less than 40 mg/10 m. Do not use copper pipes having a collapsed, deformed or discolored portion (especially on the interior surface). Otherwise, the expansion valve or capillary tube may become blocked with contaminants. As an air conditioner using R410A incurs pressure higher than when using conventional refrigerant, it is necessary to choose adequate materials. Thicknesses of copper pipes used with R410A are as shown in the table. Never use copper pipes thinner than that in the table even when it is available on the market.

Thicknesses of Annealed Copper Pipes (R410A)	
Pipe outside diameter	Thickness
6.35 mm (1/4 in.)	0.80 mm
9.52 mm (3/8 in.)	0.80 mm
12.70 mm (1/2 in.)	0.80 mm
15.88 mm (5/8 in.)	1.00 mm
19.05 mm (3/4 in.)	1.20 mm

SYSTEM LAYOUT

Layout example for the indoor units and outdoor unit

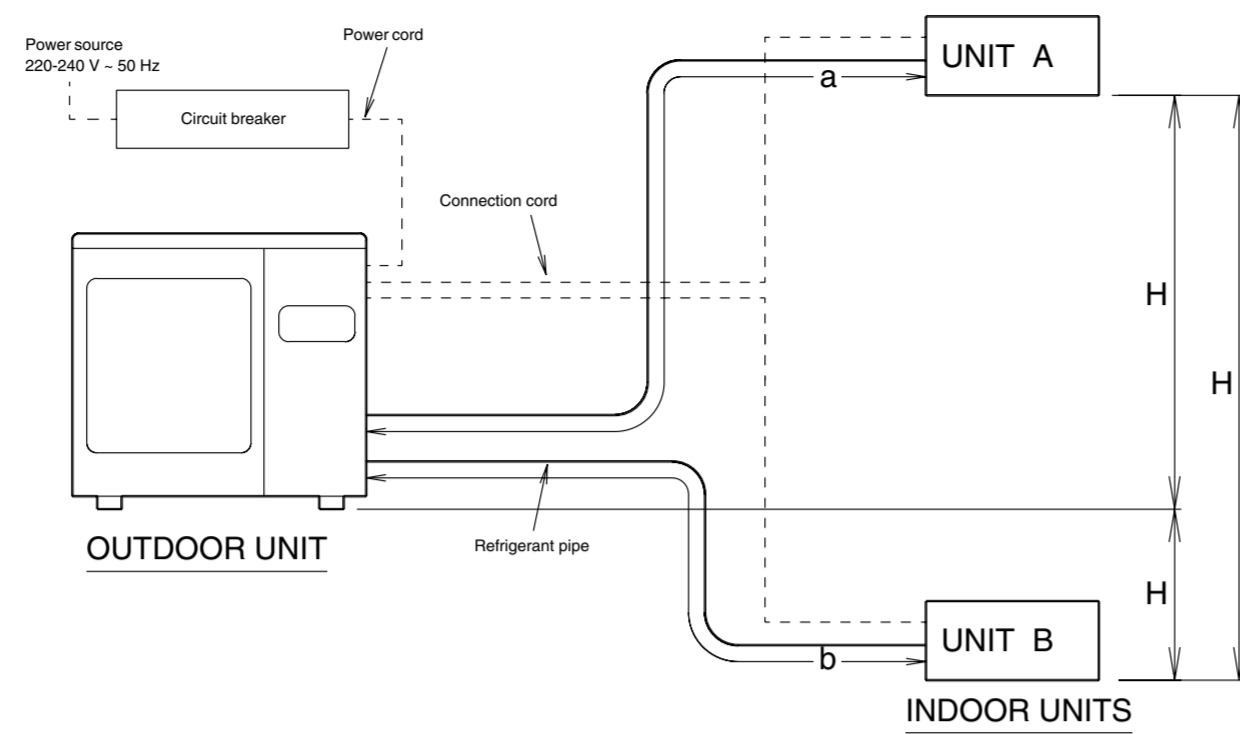

1. CONNECTABLE INDOOR UNIT CAPACITY TYPE

CAUTION

If the total capacity of the connected indoor units, an error will be displayed and the units will not operate. (For information on error displays, refer to the installation instruction sheets included with the indoor units.)

- To install an indoor unit, refer to the installation instruction sheet included with the indoor unit.
- At least three indoor units must be connected to the outdoor unit.

18 Model

Outdoor port	Connectable model name
A	7 - 12
B	7 - 12 ¹ /14

24 Model

Outdoor port	Connectable model name
A	7 - 12
B	7 - 12 ¹ /14 - 18

¹ When connecting models 7-12 to the outdoor unit, the included adapter is necessary. (For more information, refer to "4 HOW TO USE ADAPTER".)

SELECTING THE MOUNTING POSITION

WARNING

Select installation locations that can properly support the weight of the indoor and outdoor units. Install the units securely so that they do not topple or fall.

CAUTION

- Do not install where there is the danger of combustible gas leakage.
- Do not install the unit near heat source of heat, steam, or flammable gas.
- If children under 10 years old may approach the unit, take preventive measures so that they cannot reach the unit.

WARNING

- Install the unit where it will not be tilted by more than 5°.
- When installing the outdoor unit where it may be exposed to strong wind, fasten it securely.

Decide the mounting position with the customer as follows:

- Install the outdoor unit in a location which can withstand the weight of the unit and vibration, and which can install horizontally.
- Provide the indicated space to ensure good airflow.
- If possible, do not install the unit where it will be exposed to direct sunlight. (If necessary, install a blind that does not interfere with the airflow.)
- Do not install the unit near a source of heat, steam, or flammable gas.
- During heating operation, drain water flows from the outdoor unit. Therefore, install the outdoor unit in a place where the drain water flow will not be obstructed. (Reverse cycle model only)
- Do not install the unit where strong wind blows or where it is very dusty.
- Do not install the unit where people pass.
- Install the outdoor unit in a place where it will be free from being dirty or getting wet by rain as much as possible.
- Install the unit where connection to the indoor unit is easy.

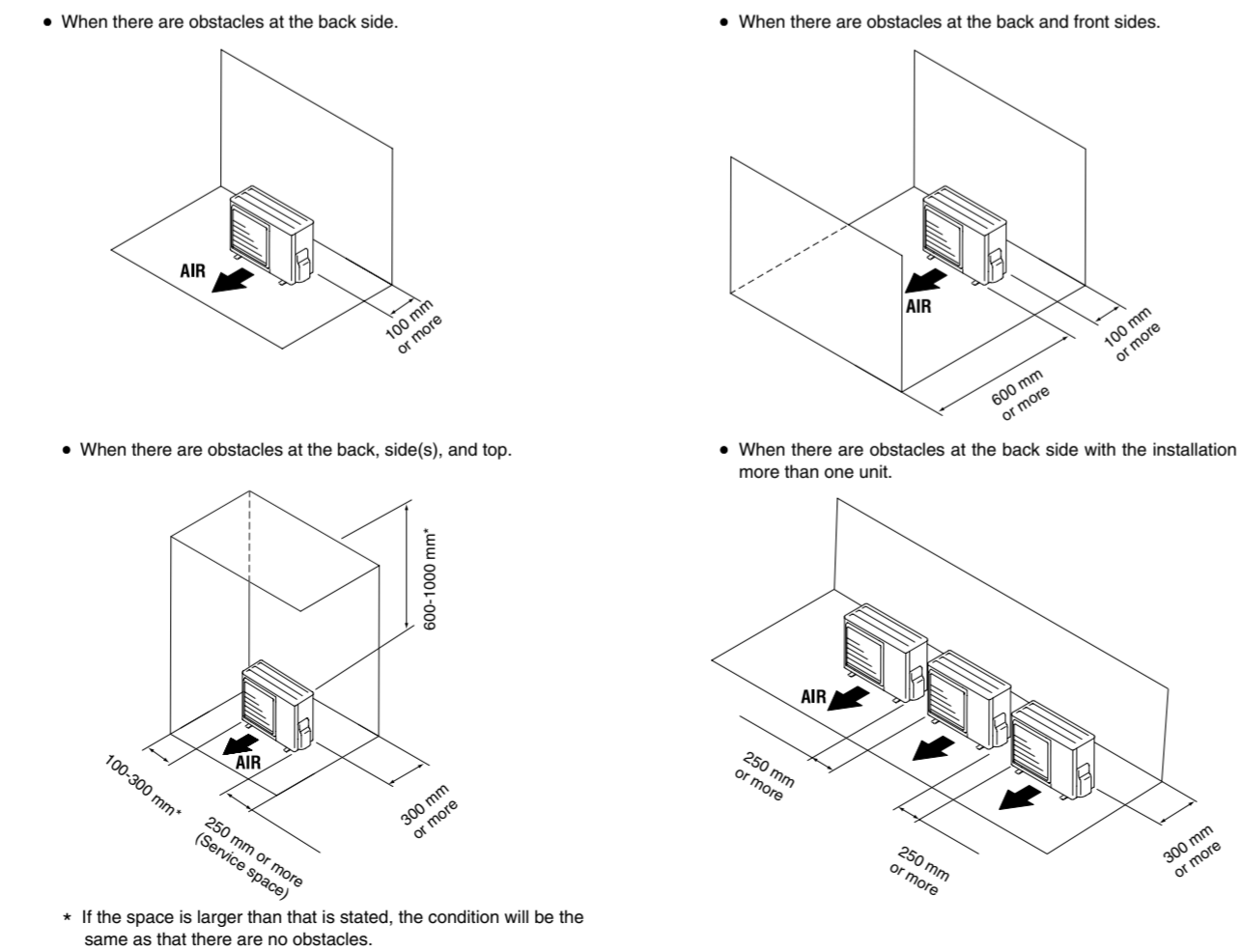

If the space is larger than that is stated, the condition will be the same as that there are no obstacles.

STANDARD PARTS

The following installation parts are furnished. Use them as required.

Name and Shape	Q'ty	Use
Drain pipe	1	For outdoor unit drain piping work [Heat & Cool model (Reverse cycle) only]
Drain cap	1	

Name and Shape	Q'ty	Use
Adapter assy	1	For use when connecting models 7-12 to outdoor port B

2. LIMITATION OF REFRIGERANT PIPING LENGTH

CAUTION

The total maximum pipe lengths and height difference of this product are shown in the table. If the units are further apart than this, correct operation cannot be guaranteed.

Total max. length (a+b)	30 m (98 ft) ²
Max. length for each indoor unit (A or B)	20 m (66 ft)
Max. height difference (H)	10 m (33 ft)
Min. length for each indoor unit (A or B)	5 m (16 ft)

² Additional refrigerant charging is not necessary.

3. SELECTING PIPE SIZES

The diameters of the connection pipes differ according to the capacity of the indoor unit. Refer to the following table for the proper diameters of the connection pipes between the indoor and outdoor units.

Capacity of indoor unit	Gas pipe size (thickness) [mm]	Liquid pipe size (thickness) [mm]
7 - 12	φ9.52 (0.8)	φ6.35 (0.8)
14 - 18	φ12.7 (0.8)	φ6.35 (0.8)

CAUTION

Operation cannot be guaranteed if the correct combination of pipes, valves, etc., is not used to connect the indoor and outdoor units.

4. HEAT INSULATION AROUND CONNECTION PIPES REQUIREMENTS

CAUTION

Install heat insulation around both the gas and liquid pipes. Failure to do so may cause water leaks. Use heat insulation with heat resistance above 120 °C. (Reverse cycle model only) In addition, if the humidity level at the installation location of the refrigerant piping is expected to exceed 70%, install heat insulation around the refrigerant piping. If the expected humidity level is 70-80%, use heat insulation that is 15 mm or thicker and if the expected humidity exceeds 80%, use heat insulation that is 20 mm or thicker. If heat insulation is used that is not as thick as specified, condensation may form on the surface of the insulation. In addition, use heat insulation with heat conductivity of 0.045 W/(m·K) or less (at 20 °C).

Connect the connection pipes according to "CONNECTING THE PIPING" in this installation instruction sheet.

5. ELECTRICAL REQUIREMENT

- Electric wire size and fuse capacity:

Power supply cord (mm ²)	MAX.	4.0
	MIN.	3.5
Connection cord (mm ²)	MAX.	2.5
	MIN.	1.5
Fuse capacity (A)	OUTDOOR UNIT	25
	INDOOR UNIT	10

- Install the disconnect device with a contact gap of at least 3 mm nearby the units.
- Always make the air conditioner power supply a special branch circuit and provide a special breaker.
- Always use H07RN-F or equivalent as the power supply cord and the connection cord.

INSTALLATION PROCEDURE

1. OUTDOOR UNIT PROCESSING

- Outdoor unit to be fasten with bolts at the four places indicated by the arrows without fail.

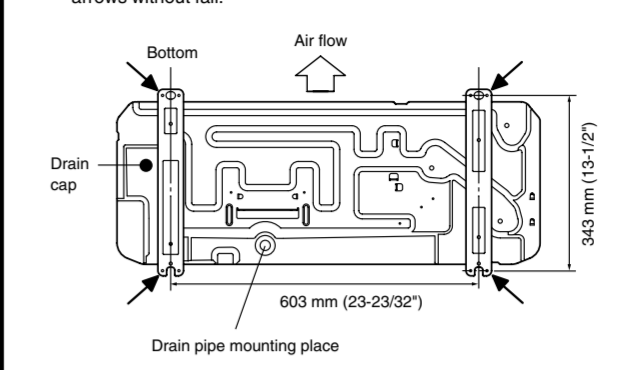

- Fix securely with bolts on a solid block. (Use 4 sets of commercially available M10 bolt, nut and washer.)

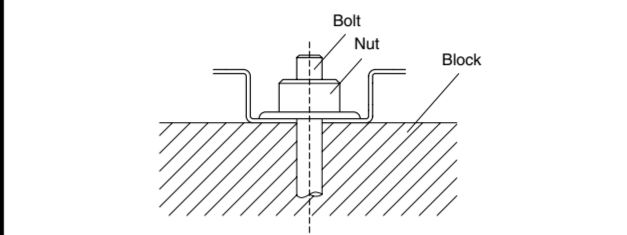

- Since the drain water flows out of the outdoor unit during heating operation, install the drain pipe and connect it to a commercial 16 mm hose. (Reverse cycle model only)
- When installing the drain pipe, plug all the holes other than the drain pipe mounting hole in the bottom of the outdoor unit with putty so there is no water leakage. (Reverse cycle model only)

CAUTION

When the outdoor temperature is 0 °C or less, do not use the accessory drain pipe and drain cap. If the drain pipe and drain cap are used, the drain water in the pipe may freeze in extremely cold weather. (Reverse cycle model only)

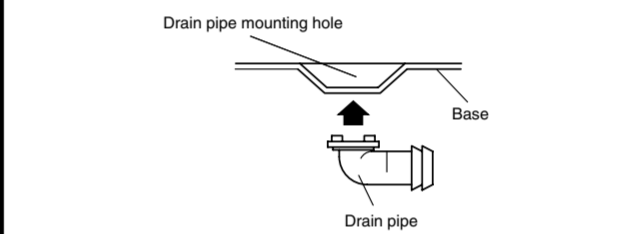

Remove outdoor unit terminal cover and valve cover.

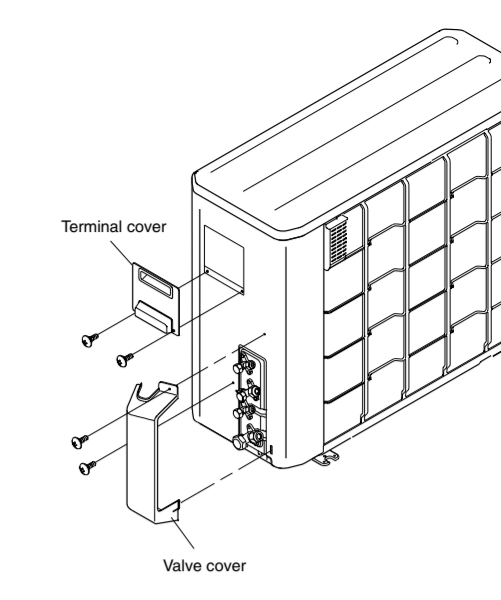

2. CONNECTING THE PIPE

CAUTION

- Do not use mineral oil on flared part. Prevent mineral oil from getting into the system as this would reduce the lifetime of the units.
- While welding the pipes, be sure to blow dry nitrogen gas through them.
- The maximum lengths of this product are shown in the table. If the units are further apart than this, correct operation cannot be guaranteed.

1. FLARING

- Cut the connection pipe to the necessary length with a pipe cutter.
- Hold the pipe downward so that cuttings will not enter the pipe and remove the burrs.
- Insert the flare nut (always use the flare nut attached to the indoor and outdoor units respectively) onto the pipe and perform the flare processing with a flare tool.

Use the special R410A flare tool, or the conventional flare tool.

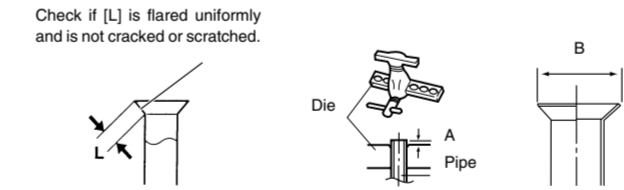

Pipe outside diameter	Dimension A (mm)
6.35 mm (1/4 in.)	Flare tool for R410A, clutch type 0 to 0.5
9.52 mm (3/8 in.)	
12.70 mm (1/2 in.)	
15.88 mm (5/8 in.)	
19.05 mm (3/4 in.)	

Pipe outside diameter	Dimension B (mm)
6.35 mm (1/4 in.)	9.1
9.52 mm (3/8 in.)	13.2
12.70 mm (1/2 in.)	16.6
15.88 mm (5/8 in.)	19.7
19.05 mm (3/4 in.)	24.0

When using conventional flare tools to flare R410A pipes, the dimension A should be approximately 0.5 mm more than indicated in the table (for flaring with R410A flare tools) to achieve the specified flaring. Use a thickness gauge to measure the dimension A.

Pipe outside diameter	Width across flats of Flare nut
6.35 mm (1/4 in.)	17 mm
9.52 mm (3/8 in.)	22 mm
12.70 mm (1/2 in.)	26 mm
15.88 mm (5/8 in.)	29 mm
19.05 mm (3/4 in.)	36 mm

2. BENDING PIPES

The pipes are shaped by your hands. Be careful not to collapse them. Do not bend the pipes in an angle more than 90°. When pipes are repeatedly bent or stretched, the material will harden, making it difficult to bend or stretch them any more. Do not bend or stretch the pipes more than three times.

CAUTION

- To prevent breaking of the pipe, avoid sharp bends. Bend the pipe with a radius of curvature of 150 mm or over.
- If the pipe is bent repeatedly at the same place, it will break.

3. CONNECTION PIPES

Outdoor unit

- Detach the caps and plugs from the pipes.

CAUTION

- Be sure to apply the pipe against the port on the indoor unit and outdoor unit correctly. If the centering is improper, the flare nut cannot be tightened smoothly. If the flare nut is forced to turn, the threads will be damaged.
- Do not remove the flare nut from the indoor unit pipe until immediately before connecting the connection pipe.

- Centering the pipe against port on the indoor unit, turn the flare nut with your hand.

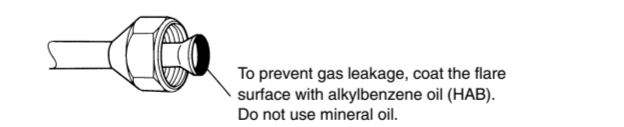

To prevent gas leakage, coat the flare surface with silysilane oil (HAB). Do not use mineral oil.

- Attach the connection pipe.
- When the flare nut is tightened properly by your hand, use a torque wrench to finally tighten it.

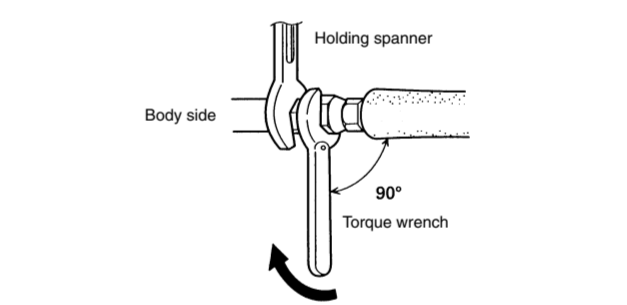

CAUTION

Hold the torque wrench at its grip, keeping it in the right angle with the pipe, in order to tighten the flare nut correctly.

Flare nut	Tightening torque
6.35 mm (1/4 in.) dia.	14 to 18 N·m (140 to 180 kgf·cm)
9.52 mm (3/8 in.) dia.	33 to 42 N·m (330 to 420 kgf·cm)
12.70 mm (1/2 in.) dia.	50 to 62 N·m (500 to 620 kgf·cm)
15.88 mm (5/8 in.) dia.	63 to 77 N·m (630 to 770 kgf·cm)
19.05 mm (3/4 in.) dia.	100 to 110 N·m (1000 to 1100 kgf·cm)

4. HOW TO USE ADAPTER (Connection ports of outdoor unit)

- When using the ADAPTER, be careful not to overtighten the nut, or the smaller pipe may be damaged.
- Apply a coat of refrigeration oil to the threaded connection part of the outdoor unit where the flare nut comes in.
- Use appropriate wrenches to avoid damaging the connection thread by overtightening the flare nut.
- Apply wrenches on both of flare nut (local part), and ADAPTER to tighten them.

Adapter tightening torque	
Adapter type	Tightening torque
φ12.7 mm → φ9.52 mm	50 to 62 [N·m] (500 to 620 kgf·cm)
φ6.35 mm → φ9.52 mm	14 to 18 [N·m] (140 to 180 kgf·cm)
φ12.7 mm → φ15.88 mm	50 to 62 [N·m] (500 to 620 kgf·cm)

5. VACUUM

- Remove the cap, and connect the gauge manifold and the vacuum pump to the charging valve by the service hoses.
- Vacuum the indoor unit and the connecting pipes until the pressure gauge indicates -0.1 MPa (-76 cmHg).
- When -0.1 MPa (-76 cmHg) is reached, operate the vacuum pump for at least 30 minutes.
- Disconnect the service hoses and fit the cap to the charging valve to the specified torque.
- Remove the blank caps, and fully open the spindles of the 2-way and 3-way valves with a hexagon wrench [Torque: 6-7 N·m (60 to 70 kgf·cm)].
- Tighten the blank caps of the 2-way valve and 3-way valve to the specified torque.

	Tightening torque	
Blank cap	6.35 mm (1/4 in.)	20 to 25 N·m (200 to 250 kgf·cm)
	9.52 mm (3/8 in.)	20 to 25 N·m (200 to 250 kgf·cm)
	12.70 mm (1/2 in.)	25 to 30 N·m (250 to 300 kgf·cm)
	15.88 mm (5/8 in.)	30 to 35 N·m (300 to 350 kgf·cm)
Charging port cap	19.05 mm (3/4 in.)	35 to 40 N·m (350 to 400 kgf·cm)
	10 to 12 N·m (100 to 120 kgf·cm)	

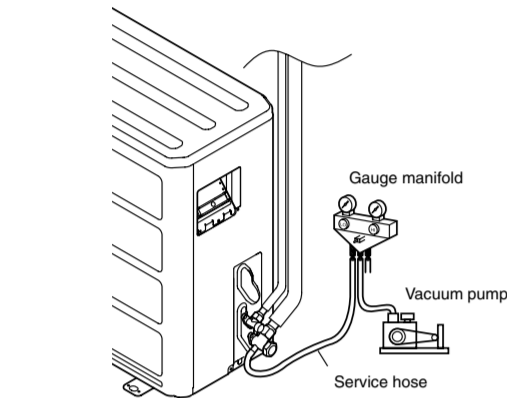
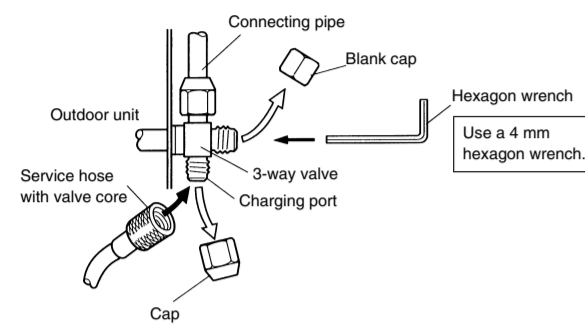

CAUTION

- Do not purge the air with refrigerants, but use a vacuum pump to vacuum the installation! There is no extra refrigerant in the outdoor unit for air purging!
- Use a vacuum pump and gauge manifold and charging hose for R410A exclusively. Using the same vacuum for different refrigerants may damage the vacuum pump or the unit.
- Charging of additional refrigerant (R410A) according to the piping length is unnecessary.

6. GAS LEAKAGE INSPECTION

CAUTION

- After connecting the piping, check the all joints for gas leakage with gas leak detector.
- When inspecting gas leakage, always use the vacuum pump for pressure. Do not use nitrogen gas.

7. RECHARGING THE REFRIGERANT

CAUTION

- When moving and installing the air conditioner, do not mix gas other than the specified refrigerant (R410A) inside the refrigerant cycle.
- When charging the refrigerant R410A, always use an electronic balance for refrigerant charging (to measure the refrigerant by weight).
- When charging the refrigerant, take into account the slight change in the composition of the gas and liquid phases, and always charge from the liquid phase side whose composition is stable.
- Add refrigerant from the charging valve after the completion of the work.
- If the units are further apart than the maximum pipe length, correct operation can not be guaranteed.

3

POWER

WARNING

- The rated voltage of this product is 220-240 V A.C. 50 Hz.
- Before turning on verify that the voltage is within the 198 V to 264 V range.
- Always use a special branch circuit and install a special receptacle to supply power to the air conditioner.
- Use a special branch circuit breaker and receptacle matched to the capacity of the air conditioner. (Install in accordance with standard.)
- Perform wiring work in accordance with standards so that the air conditioner can be operated safely and positively.
- Install a leakage special branch circuit breaker in accordance with the related laws and regulations and electric company standards.

CAUTION

- The power source capacity must be the sum of the air conditioner current and the current of other electrical appliances. When the current contracted capacity is insufficient, change the contracted capacity.
- When the voltage is low and the air conditioner is difficult to start, contact the power company the voltage raised.

4

ELECTRICAL WIRING

WARNING

- Before starting work, check that power is not being supplied to the indoor unit and outdoor unit.
- Match the terminal board numbers and connection cord colors with those of the outdoor unit. Erroneous wiring may cause burning of the electric parts.
- Connect the connection cords firmly to the terminal board. Imperfect installation may cause a fire.
- Always fasten the outside covering of the connection cord with the cord clamp. (If the insulator is chafed, electric leakage may occur.)
- Always connect the ground wire.

HOW TO CONNECT WIRING TO THE TERMINALS

A. For solid core wiring (or F-cable)

- Cut the wire end with a wire cutter or wire-cutting pliers, then strip the insulation to about 25 mm to expose the solid wire.
- Using a screwdriver, remove the terminal screw(s) on the terminal board.
- Using pliers, bend the solid wire to form a loop suitable for the terminal screw.
- Shape the loop wire properly, place it on the terminal board and tighten securely with the terminal screw using a screwdriver.

B. For strand wiring

- Cut the wire end with a wire cutter or wire-cutting pliers, then strip the insulation to about 10 mm to expose the strand wiring.
- Using a screwdriver, remove the terminal screw(s) on the terminal board.
- Using a round terminal fastener or pliers, securely clamp a round terminal to each stripped wire end.
- Position the round terminal wire, and replace and tighten the terminal screw using a screwdriver.

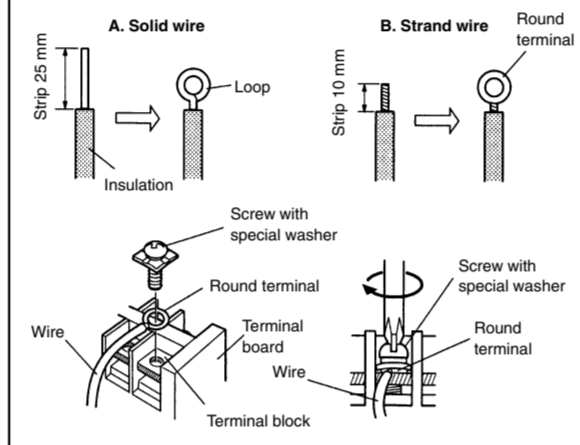

1. CONNECTION DIAGRAMS

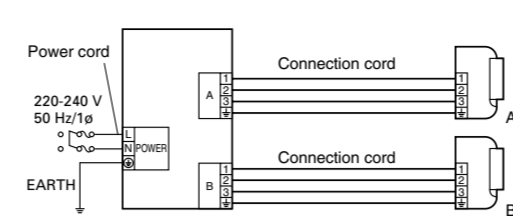

2. CORD PREPARATION

Keep the earth wire longer than the other wires.

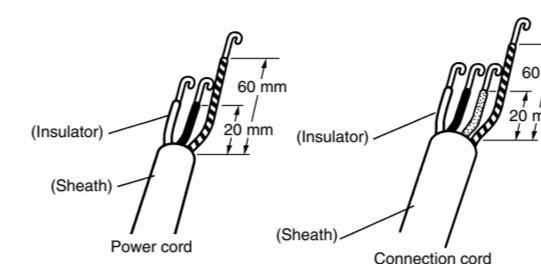

3. OUTDOOR UNIT

- Connect the power supply cord and the connection cord to terminal.
- Fasten the power supply cord and connection cord with cord clamp.

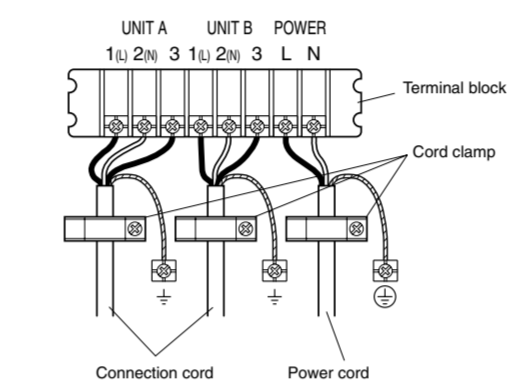

- Pass the connection cord and power cord through the hole of the 3-way valve bracket and run them to the outside of the cabinet.

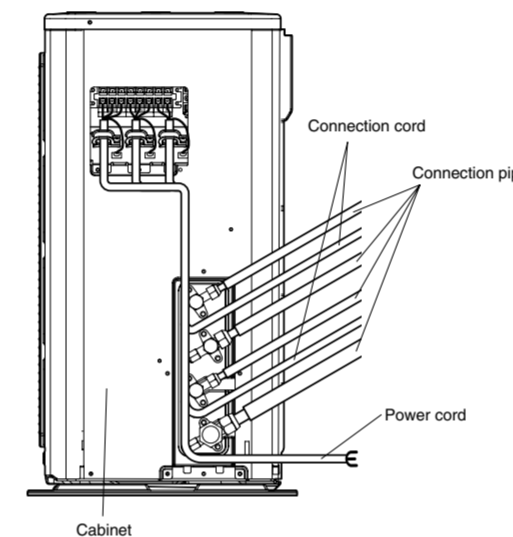

- Install the valve cover and terminal cover as shown. Pass the power cord and connections cords through the valve cover when wiring them.

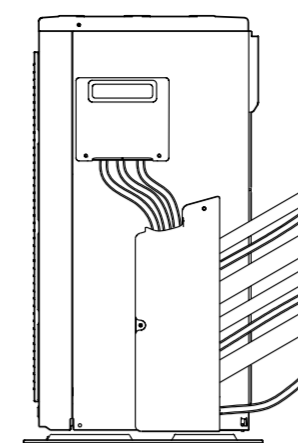

5

TEST RUNNING

The test run method may be different for each indoor unit that is connected. Refer to the installation instruction sheet included with each indoor unit.

6

CUSTOMER GUIDANCE

Explain the following to the customer in accordance with the operating manual:

- Starting and stopping method, operation switching, temperature adjustment, timer, air flow adjustment, and other remote control unit operations.
- Air filter removal and cleaning.
- Give the operating manual and installation instruction sheet to the customer.