

Refrigerant R410A Duct Type

SPLIT TYPE AIR CONDITIONER INSTALLATION INSTRUCTION SHEET

(PART NO. 9357874098)

- WARNING** This mark indicates procedures which, if improperly performed, might lead to the death or serious injury of the user.
- CAUTION** This mark indicates procedures which, if improperly performed, might possibly result in personal harm to the user, or damage to property.

This air conditioner uses new refrigerant HFC (R410A).

The basic installation work procedures are the same as conventional refrigerant (R22) models. However, pay careful attention to the following points:

- Since the working pressure is 1.6 times higher than that of conventional refrigerant (R22) models, some of the piping and installation and service tools are special. (See the table below.) Especially, when replacing a conventional refrigerant (R22) model with a new refrigerant R410A model, always replace the conventional piping and flare nuts with the R410A piping and flare nuts.
- Models that use refrigerant R410A have a different charging port thread diameter to prevent erroneous charging with conventional refrigerant (R22) and for safety. Therefore, check beforehand. (The charging port thread diameter for R410A is 1/2 UNF 20 threads per inch.)
- Be more careful that foreign matter (oil, water, etc.) does not enter the piping than with refrigerant (R22) models. Also, when storing the piping, securely seal the openings by pinching, taping, etc.
- When charging the refrigerant, take into account the slight change in the composition of the gas and liquid phases, and always charge from the liquid phase side whose composition is stable.

Special tools for R410A

Tool name	Contents of change
Gauge manifold	Pressure is high and cannot be measured with a conventional gauge. To prevent erroneous mixing of other refrigerants, the diameter of each port has been changed. It is recommended the gauge with seals ~ 0.1 to 5.3 MPa (~ 76 cmHg to 53 kgf/cm ²) for high pressure. ~ 0.1 to 3.8 MPa (~ 76 cmHg to 38 kgf/cm ²) for low pressure. To increase pressure resistance, the hose material and base size were changed.
Charge hose	A conventional vacuum pump can be used by installing a vacuum pump adapter.
Vacuum pump	Special gas leakage detector for HFC refrigerant R410A.
Gas leakage detector	

Copper pipes

It is necessary to use seamless copper pipes and it is desirable that the amount of residual oil is less than 0.1 g. Do not use copper pipes having a collapsed, deformed or discolored portion (especially on the interior surface). Otherwise, the expansion valve or capillary tube may become blocked with contaminants.

As an air conditioner using R410A incurs pressure higher than when using R22, it is necessary to choose adequate materials. Thicknesses of copper pipes used with R410A are as shown in Table 1. Never use copper pipes thinner than 0.8 mm (Nominal diameter is 3/8 in., 1.0 mm (Nominal diameter is 5/8 in.) even when it is available on the market.

Table 1 Thicknesses of Annealed Copper Pipes

Nominal diameter (Inch)	Outer diameter (mm)	Thickness (mm)	
		R410A	[ref.] R22
3/8	9.52	0.80	0.80
5/8	15.88	1.00	1.00

For authorized service personnel only.

- WARNING**
- For the air conditioner to operate satisfactorily, install it as outlined in this installation instruction sheet.
- Connect the indoor unit and outdoor unit with the air conditioner piping and cords available standards parts. This installation instruction sheet describes the correct connections using the installation set available from our standard parts.
- Installation work must be performed in accordance with national wiring standards by authorized personnel only.
- If refrigerant leaks while work is being carried out, ventilate the area. If the refrigerant comes in contact with a flame, it produces a toxic gas.
- Do not use an extension cord.
- Do not turn on the power until all installation work is complete.

- Be careful not to scratch the air conditioner when handling it.
- After installation, explain correct operation to the customer, using the operating manual.
- Let the customer keep this installation instruction sheet because it is used when the air conditioner is serviced or moved.

SELECTING THE MOUNTING POSITION

- WARNING**
- Install at a place that can withstand the weight of the indoor and outdoor units and install positively so that the units will not topple or fall.

- CAUTION**
- Do not install where there is the danger of combustible gas leakage.
- Do not install the unit near heat source of heat, steam, or flammable gas.
- If children under 10 years old may approach the unit, take preventive measures so that they cannot reach the unit.

Decide the mounting position with the customer as follows:

INDOOR UNIT

- Install the indoor unit on a place having a sufficient strength so that it withstands against the weight of the indoor unit.
- The inlet and outlet ports should not be obstructed; the air should be able to blow all over the room.
- Leave the space required to service the air conditioner (Fig. 1).
- Install the unit where the drain pipe can be easily installed.
- Providing as much space as possible between the indoor unit and the ceiling will make work much easier.

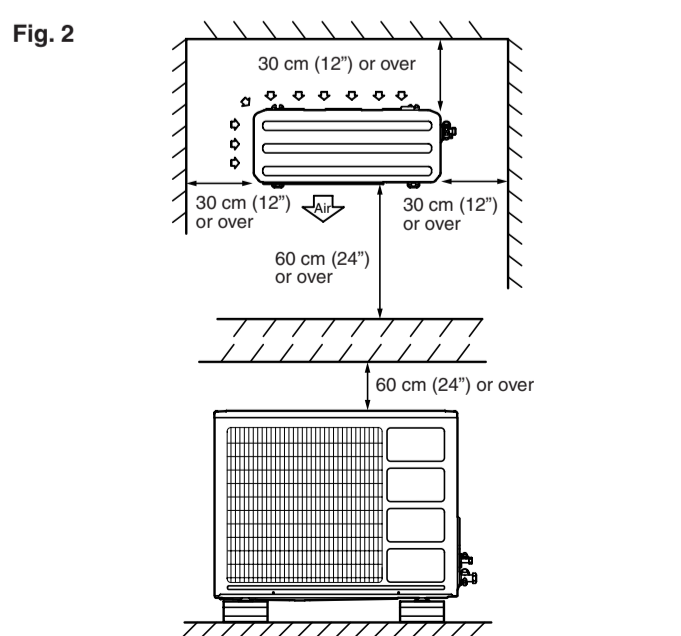
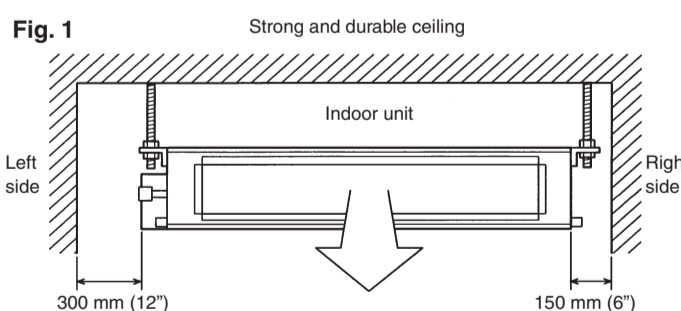

OUTDOOR UNIT

- WARNING**
- Install the unit where it will not be tilted by more than 5°.
- When installing the outdoor unit where it may be exposed to strong wind, fasten it securely.

- If possible, do not install the unit where it will be exposed to direct sunlight. (If necessary, install a blind that does not interfere with the air flow.)
- Install the outdoor unit in a place where it will be free from being dirty or getting wet by rain as much as possible.
- Install the unit when connection to the indoor unit is easy.
- During heating operation, drain water flows from the outdoor unit. Therefore, install the outdoor unit in a place where the drain water flow will not be obstructed.
- Do not place animals and plants in the path of the warm air.
- Take the air conditioner weight into account and select a place where noise and vibration are small.
- Select a place so that the warm air and noise from the air conditioner do not disturb neighbors.
- Provide the space shown in Fig. 2 so that the air flow is not blocked. Also for efficient operation, leave open three of the four directions front, rear, and both sides.

STANDARD PARTS

The following installation parts are furnished. Use them as required.

INDOOR UNIT ACCESSORIES

Name and Shape	Q'ty	Application
Installation template	1	For positioning the indoor unit
Hanger	4	For suspending the indoor unit from ceiling
Special nut A (large flange)	4	For suspending the indoor unit from ceiling
Special nut B (small flange)	4	For suspending the indoor unit from ceiling
Coupler heat insulation (large)	1	For indoor side pipe joint (large pipe)
Coupler heat insulation (small)	1	For indoor side pipe joint (small pipe)
Blinder	1 (large)	For fixing the drain hose
Remote controller	1 (small)	For fixing the remote controller cord
Remote controller	1	
Remote controller cord	1	
Remote controller cord	1	For connecting the remote controller
Drain hose insulation	1	Insulates the drain hose and vinyl hose connection

OUTDOOR UNIT ACCESSORIES

Drain pipe	1	For outdoor unit drain piping work [Heat & Cool model (Reverse cycle) only]
Drain cap	1	

INSTALLATION PROCEDURE

Install the air conditioner as follows:

1 INDOOR UNIT INSTALLATION

- WARNING**
- Install the air conditioner in a location which can withstand a load of at least five times the weight of the main unit and which will not amplify sound or vibration. If the installation location is not strong enough, the indoor unit may fall and cause injuries.
- If the job is done with the panel frame only, there is a risk that the unit will come loose. Please take care.

1. DRILLING HOLES FOR BOLTS AND INSTALLING THE BOLTS

- Using the installation template, drill holes for bolts (four holes). (Fig. 3)

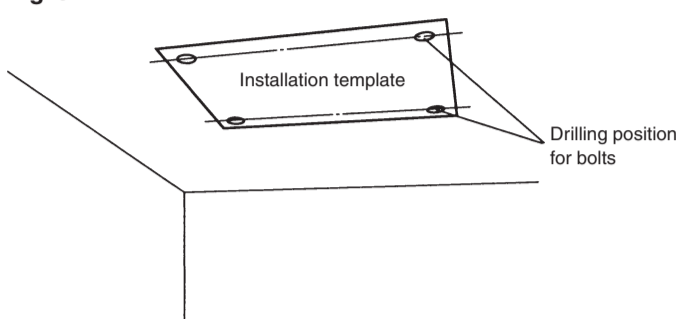

2. INSTALLING THE HANGERS

- Fasten the hanging bolts to the ceiling and install special nuts A and B.

Bolt Strength	9.81 to 14.71 N·m (100 to 150 kgf·cm)
---------------	---------------------------------------

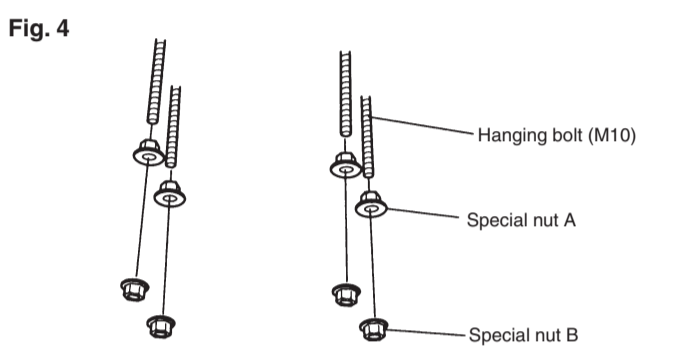

- Install the hangers to the unit.

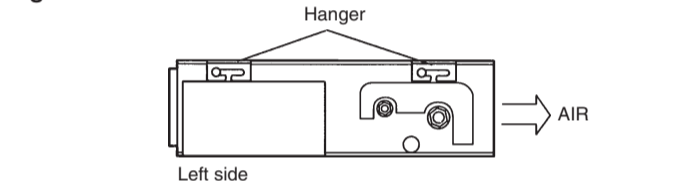

- WARNING**
- When fastening the hangers, make the bolt positions uniform.

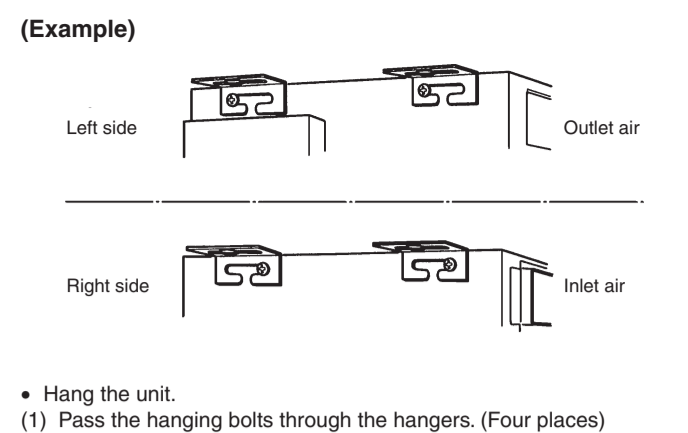

- Hang the unit. (1) Pass the hanging bolts through the hangers. (Four places)

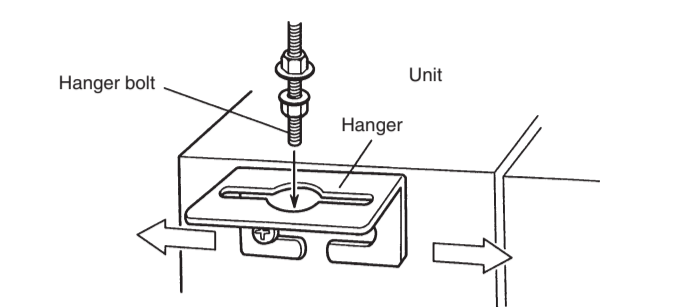

- Slide the unit in the arrow direction and fasten it.

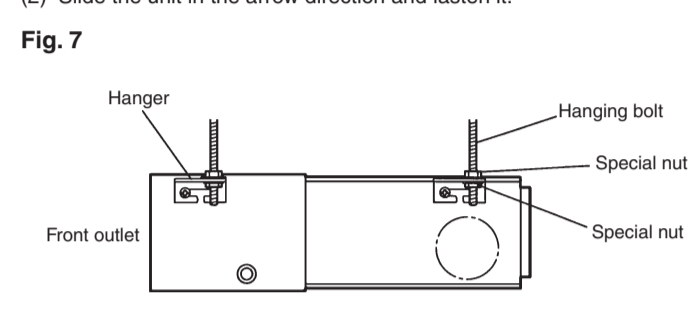

- WARNING**
- Fasten the unit securely with special nuts A and B.

- Install the bolts to the ceiling at a place strong enough to hang the unit. Mark the bolt positions from the installation template. With a concrete drill, drill for 12.7 mm (1/2") dia. holes. (Fig. 8)

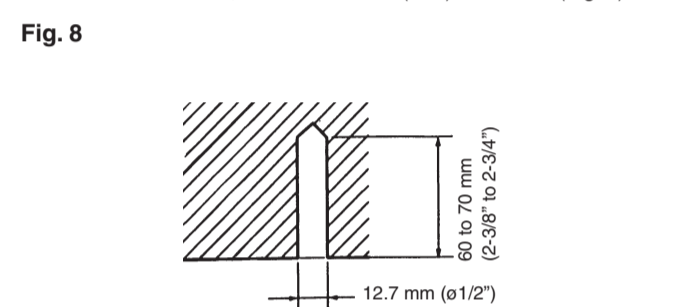

- CAUTION**
- Be sure to connect the large pipe after connecting the small pipe completely.

CONNECTION PIPE REQUIREMENT

Diameter		Maximum length	Maximum Height (between indoor and outdoor)
Small	Large		
9.52 mm (3/8 in.)	15.88 mm (5/8 in.)	25 m (80 ft)	15 m (49 ft)

- Use pipe with water-resistant heat insulation.

- CAUTION**
- Install heat insulation around both the gas and liquid pipes. Failure to do so may cause water leaks. Use heat insulation with heat resistance above 120 °C. (Reverse cycle model only)

In addition, if the humidity level at the installation location of the refrigerant piping is expected to exceed 70%, install heat insulation around the refrigerant piping. If the expected humidity level is 70-80%, use heat insulation that is 15 mm or thicker and if the expected humidity exceeds 80%, use heat insulation that is 20 mm or thicker. If heat insulation is used that is not as thick as specified, condensation may form on the surface of the insulation. In addition, use heat insulation with heat conductivity of 0.045 W/(m·K) or less (at 20 °C).

ELECTRICAL REQUIREMENT

- Electric wire size and fuse capacity:

Power supply cord (mm ²)	MAX.		4.0
	MIN.	3.5	
Connection cord (mm ²)	MAX.		2.5
	MIN.		1.5
Fuse capacity (A)	30		

- Install the disconnect device with a contact gap of at least 3 mm nearby the units. (Both indoor unit and outdoor unit)

3 CONNECTING THE PIPING

- WARNING**
- Do not use the existing (for R22) piping and flare nuts. If the existing materials are used, the pressure inside the refrigerant cycle will rise and cause breakage, injury, etc. (Use the special R410A materials.)

- CAUTION**
- Do not use mineral oil on flared part. Prevent mineral oil from getting into the system as this would reduce the lifetime of the units.

- While welding the pipes, be sure to blow dry nitrogen gas through them.

- The maximum lengths of this product are shown in table 2. If the units are further apart than this, correct operation can not be guaranteed.

1. FLARING

- Cut the connection pipe to the necessary length with a pipe cutter.
- Hold the pipe downward so that cuttings will not enter the pipe and remove the burrs.
- Insert the flare nut (always use the flare nut attached to the indoor and outdoor units respectively) onto the pipe and perform the flare processing with a flare tool. Use the special R410A flare tool, or the conventional (for R22) flare tool. When using the conventional flare tool, always use an allowance adjustment gauge and secure the A dimension shown in table 4.

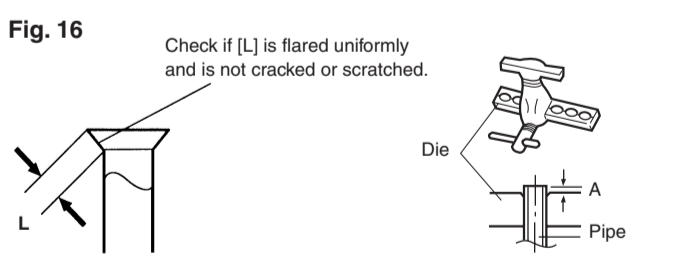

Pipe outside diameter	A (mm)		
	Flare tool for R410A, clutch type	Conventional (R22) flare tool Clutch type	Wing nut type
9.52 mm (3/8 in.)	0 to 0.5	1.0 to 1.5	1.5 to 2.0
15.88 mm (5/8 in.)	0 to 0.5	1.0 to 1.5	2.0 to 2.5

2. BENDING PIPES

- The pipes are shaped by your hands. Be careful not to collapse them.

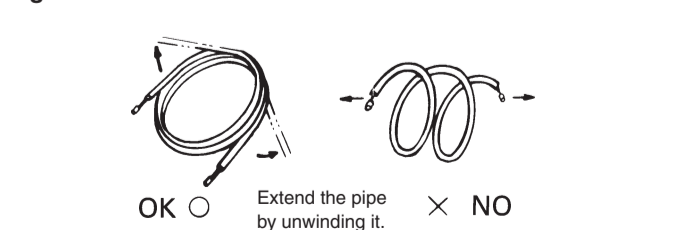

- Do not bend the pipes in an angle more than 90°. When pipes are repeatedly bent or stretched, the material will harden, making it difficult to bend or stretch them any more. Do not bend or stretch the pipes more than three times.

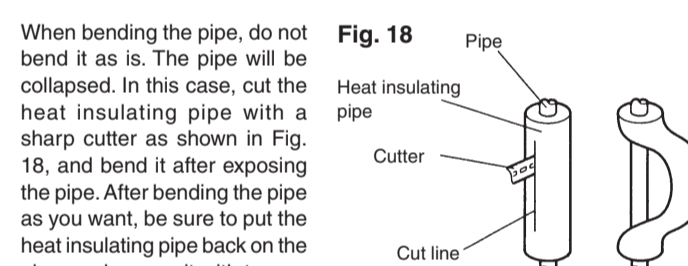

- CAUTION**
- To prevent breaking of the pipe, avoid sharp bends. Bend the pipe with a radius of curvature of 150 mm or over.
- If the pipe is bent repeatedly at the same place, it will break.

3. CONNECTION PIPES

- Indoor unit side
- Detach the caps and plugs from the pipes.

- CAUTION**
- Be sure to apply the pipe against the port on the indoor unit correctly. If the centering is improper, the flare nut cannot be tightened smoothly. If the flare nut is forced to turn, the threads will be damaged.

- Do not remove the flare nut from the indoor unit pipe until immediately before connecting the connection pipe.

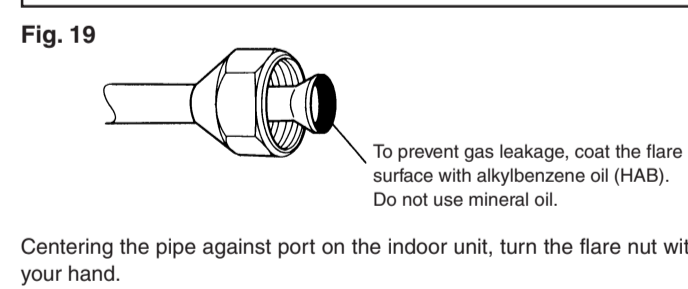

- CAUTION**
- Hold the torque wrench at its grip, keeping it in the right angle with the pipe as shown in Fig. 21, in order to tighten the flare nut correctly.

- When the flare nut is tightened properly by your hand, use a torque wrench to finally tighten it.

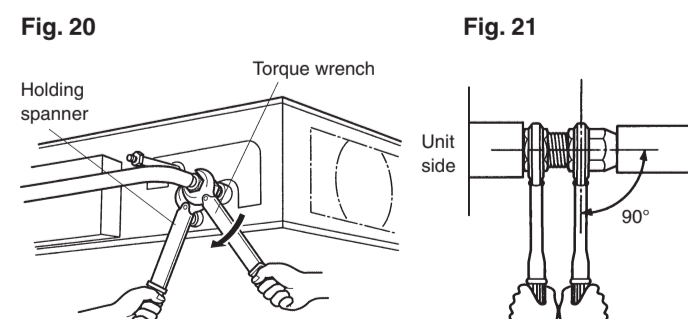

Flare nut	Tightening torque
9.52 mm (3/8 in.) dia.	33 to 42 N·m (330 to 420 kgf·cm)
15.88 mm (5/8 in.) dia.	63 to 77 N·m (630 to 770 kgf·cm)

- Insert the anchor bolts into the drilled holes, and drive the pins completely into the anchor bolts with a hammer.

Anchor-Bolt Strength	9.81 to 14.71 N·m (100 to 150 kgf·cm)
----------------------	---------------------------------------

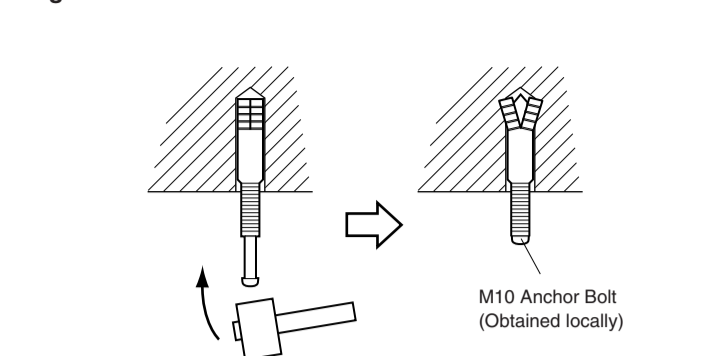

- Install the hangers to the unit

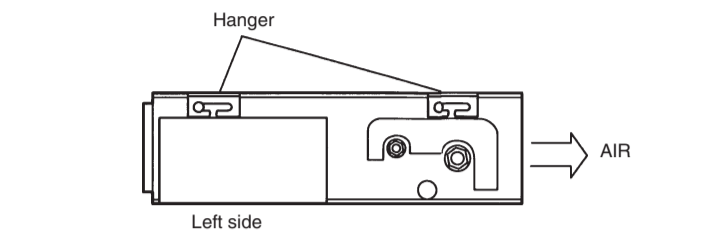

- WARNING**
- When fastening the hangers, make the bolt positions uniform.

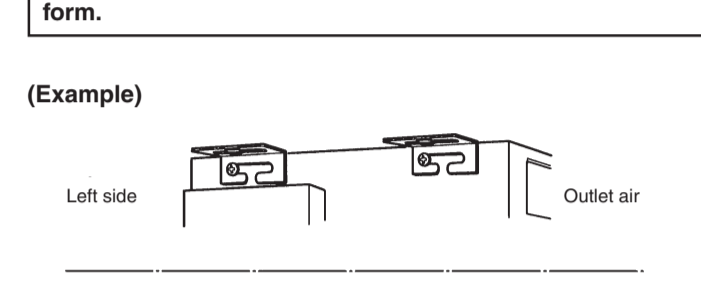

- Install the unit
- Pass the unit hangers over the bolts installed to the ceiling and install the unit with the special nut B.

- CAUTION**
- There should be no gaps between the insulation and the product.

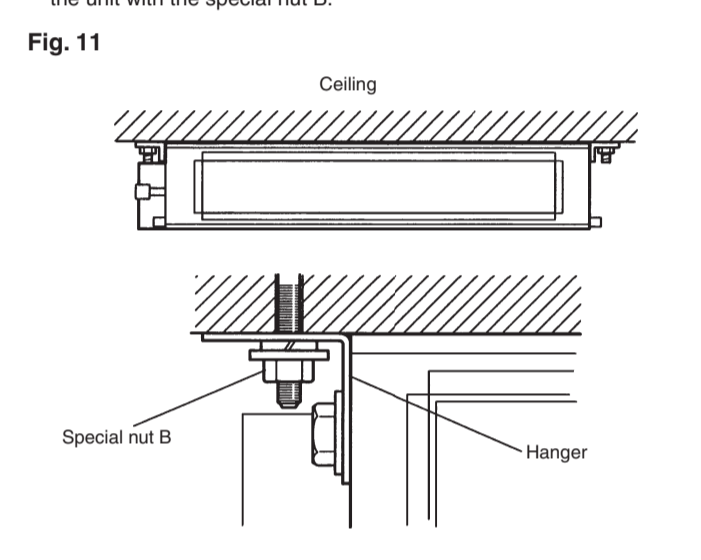

3. LEVELING

- Base horizontal direction leveling on top of the unit.

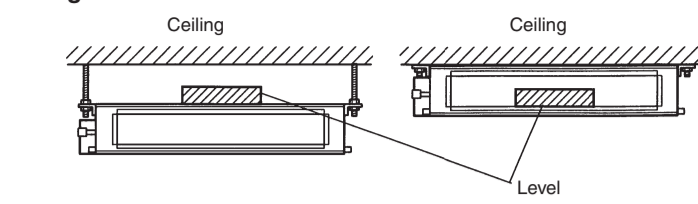

- Base vertical direction leveling on the unit (right and left).

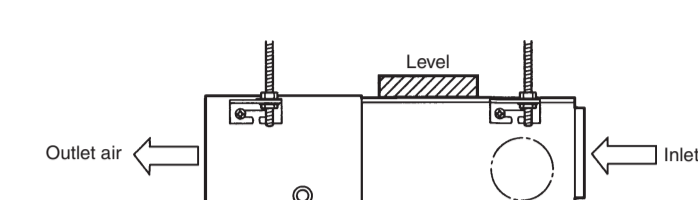

- It shall be possible to install and remove the control box metal.

4. SERVICE HOLE DIMENSIONS

- Vertical dimension
- Horizontal dimension

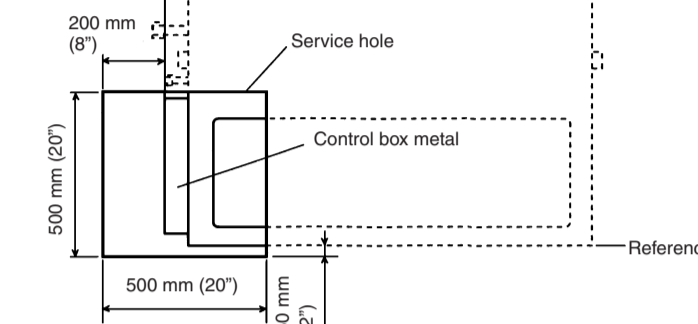

- Vertical dimension
- Horizontal dimension

2 OUTDOOR UNIT INSTALLATION

- WARNING**
- Install the unit where it will not be tilted by more than 5°.
- When installing the outdoor unit where it may be exposed to strong wind, fasten it securely.

- Set the unit on a strong stand, such as one made of concrete blocks to minimize shock and vibration.
- Do not set the unit directly on the ground because it will cause trouble.
- Since the drain water flows out of the outdoor unit during heating operation, install the drain pipe and connect it to an commercial 16 mm hose. (Heat & Cool model (Reverse cycle) only)
- When installing the drain pipe, plug all the holes (hole at one place) other than the drain pipe mounting hole in the bottom of the outdoor unit with putty so there is no water leakage. (Fig. 15) (Heat & Cool model (Reverse cycle) only)

- CAUTION**
- Installation in cold regions. Do not use the accessory drain pipe and drain cap. (If the drain pipe and drain cap are used, the drain water in the pipe may freeze in extremely cold weather.)

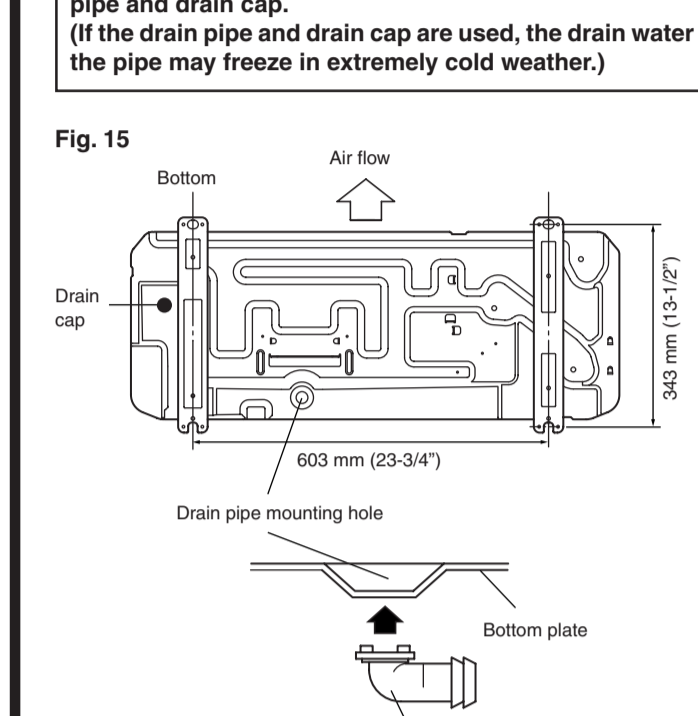

4 VACUUM PROCESS

- CAUTION**
- Do not purge the air with refrigerants but use a vacuum pump to vacuum the installation! There is no extra refrigerant in the outdoor unit for air purging!
- Use a vacuum pump for R410A exclusively. Using the same vacuum pump for different refrigerants may damage the vacuum pump or the unit.

1. VACUUM

- Remove the cap, and connect the gauge manifold and the vacuum pump to the charging valve by the service hoses.
- Vacuum the indoor unit and the connecting pipes until the pressure gauge indicates ~ 0.1 MPa (~ 76 cmHg).
- When ~ 0.1 MPa (~ 76 cmHg) is reached, operate the vacuum pump for at least 15 minutes.
- Disconnect the service hoses and fit the cap to the charging valve to the specified torque.
- Remove the blank caps, and fully open the spindles of the 2-way and 3-way valves with a hexagon wrench (Torque: 6 to 7 N·m (60 to 70 kgf·cm)).
- Tighten the blank caps of the 2-way valve and 3-way valve to the specified torque.

Table 6		Tightening torque
Blank cap (2-way valve)	20 to 25 N·m (200 to 250 kgf·cm)	
Blank cap (3-way valve)	30 to 35 N·m (300 to 350 kgf·cm)	
Charging port cap	10 to 12 N·m (100 to 120 kgf·cm)	

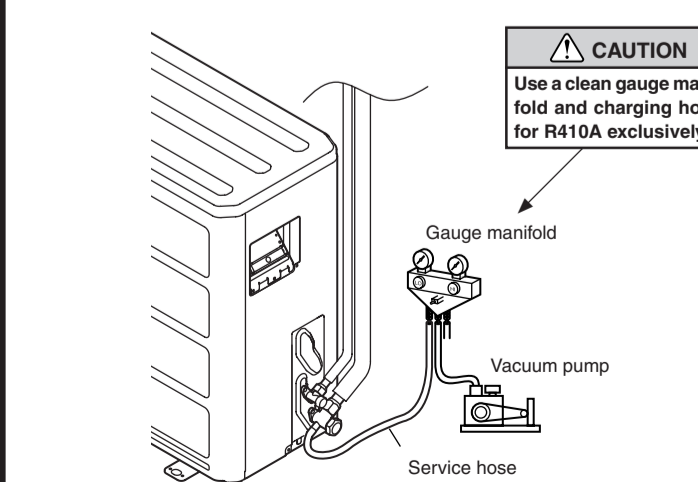
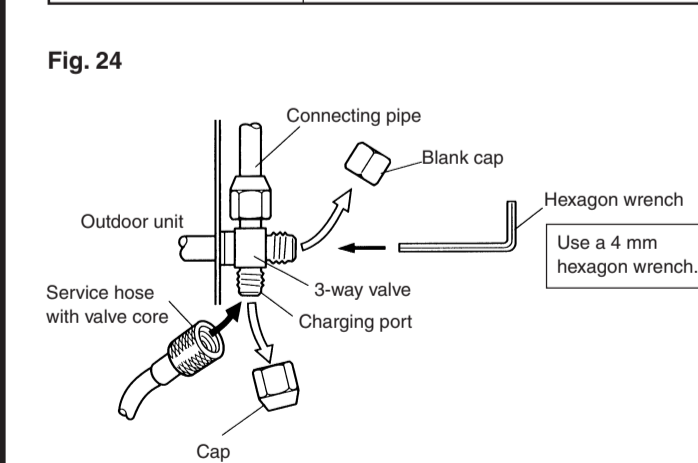

2. ADDITIONAL CHARGE

Refrigerant suitable for a piping length of 7.5 m is charged in the outdoor unit at the factory. When the piping is longer than 7.5 m, additional charging is necessary. For the additional amount, see the table below.

Additional refrigerant	Table 7					
	Pipe length	7.5 m (25 ft)	10 m (33 ft)	15 m (49 ft)	20 m (66 ft)	25 m (82 ft)
Heat & Cool (Reverse cycle)	None	100 g (3.5 oz)	300 g (10.6 oz)	500 g (17.6 oz)	700 g (24.7 oz)	
	Cooling model	None	50 g (1.8 oz)	150 g (5.3 oz)	250 g (8.9 oz)	350 g (12.3 oz)

Between 7.5 m and 25 m, when using a connection pipe other than that in the table, charge additional refrigerant with 40 g (1.4 oz)/1 m (3.3 ft) (Reverse cycle model), 20 g (0.7 oz)/1 m (3.3 ft) (Cooling model) as the criteria.

- CAUTION**
- When moving and installing the air conditioner, do not mix gas other than the specified refrigerant (R410A) inside the refrigerant cycle.
- When charging the refrigerant R410A, always use an electronic balance for refrigerant charging (to measure the refrigerant by weight).
- When charging the refrigerant, take into account the slight change in the composition of the gas and liquid phases, and always charge from the liquid phase side whose composition is stable.
- Add refrigerant from the charging valve after the completion of the work.
- If the units are further apart than the maximum pipe length, correct operation can not be guaranteed.

5 GAS LEAKAGE INSPECTION

- CAUTION**
- After connecting the piping, check the joints for gas leakage with gas leak detector.

6 INSTALLING DRAIN HOSE

- When the unit is shipped from the factory, the drain port is on the left side (control box side).
- When using the drain port on the right side of the unit, reinstall the drain cap to the left side drain port.

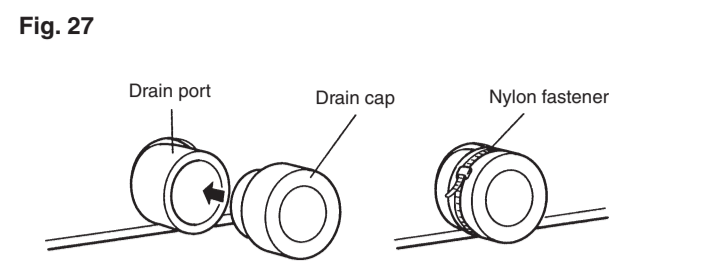

NOTE : INSTALL THE DRAIN HOSE

- Install the drain hose with downward gradient (1/50 to 1/100) and so there are no rises or traps in the hose.
- Use general hard polyvinyl chloride pipe (VP25) [outside diameter 38 mm] and connect it with adhesive (polyvinyl chloride) so that there is no leakage.
- When the hose is long, install supporters.
- Do not perform air bleeding.
- Always heat insulate the indoor side of the drain hose.

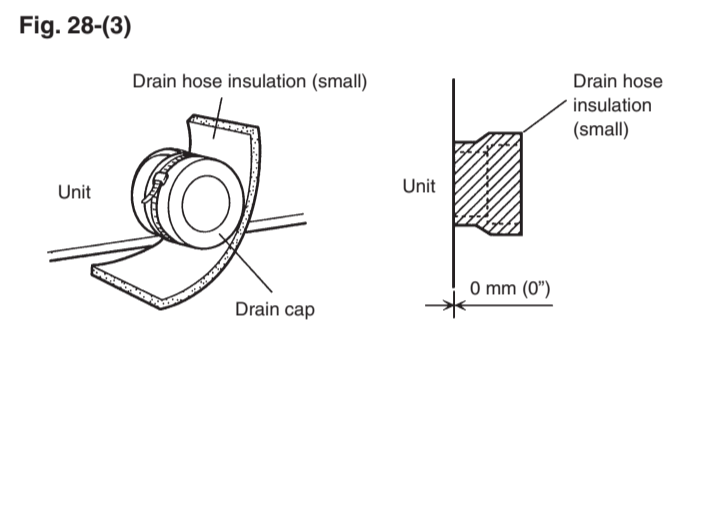
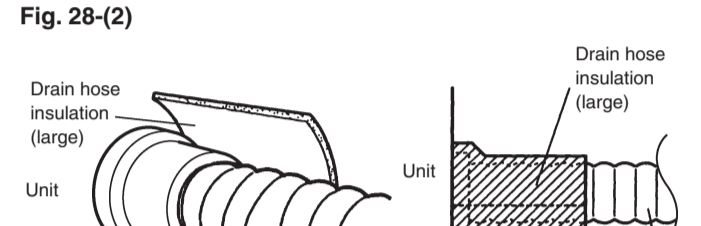
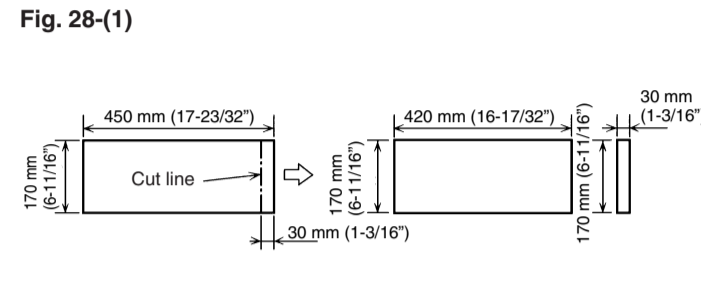
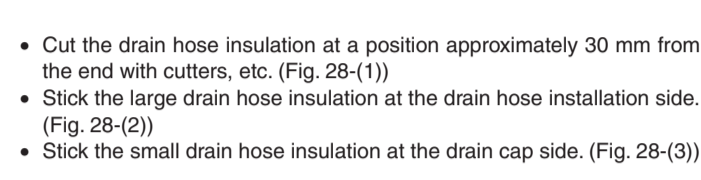

- The outside diameter of the drain port is 38 mm. Use a suitable drain hose.
- There is a drain port on both the left and right sides. Select the drain port to match the local conditions.

7 ELECTRICAL WIRING

HOW TO CONNECT WIRING TO THE TERMINALS

- A. For solid core wiring (or F-cable)**
- Cut the wire end with a wire cutter or wire-cutting pliers, then strip the insulation to about 25 mm (15/16") of expose the solid wire.
 - Using a screwdriver, remove the terminal screw(s) on the terminal board.
 - Using pliers, bend the solid wire to form a loop suitable for the terminal screw.
 - Shape the loop wire properly, place it on the terminal board and tighten securely with the terminal screw using a screwdriver.
- B. For strand wiring**
- Cut the wire end with a wire cutter or wire-cutting pliers, then strip the insulation to about 10 mm (3/8") of expose the strand wiring.
 - Using a screwdriver, remove the terminal screw(s) on the terminal board.
 - Using a round terminal fastener or pliers, securely clamp a round terminal to each stripped wire end.
 - Position the round terminal wire, and replace and tighten the terminal screw with a screwdriver.

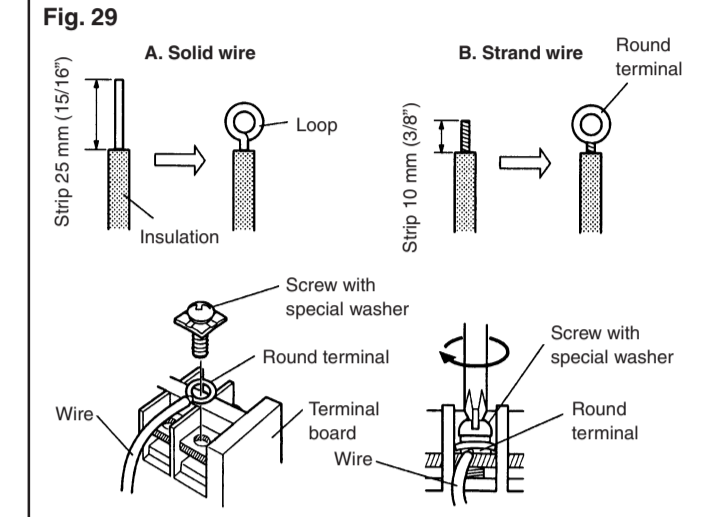

HOW TO FIXED CONNECTION CORD AND POWER CORD AT THE CORD CLAMP

After passing the connection cord and power cord through the insulation tube, fasten it with the cord clamp.

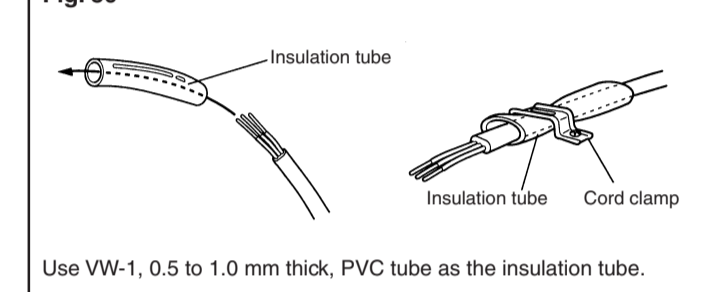

CAUTION
Use VW-1, 0.5 to 1.0 mm thick, PVC tube as the insulation tube.

1. INDOOR UNIT SIDE

- WARNING**
- Before starting work, check that power is not being supplied to the indoor unit and outdoor unit.
 - Match the terminal board numbers and connection cord colors with those of the outdoor unit. Erroneous wiring may cause burning of the electric parts.
 - Connect the connection cords firmly to the terminal board. Imperfect installation may cause a fire.
 - Always fasten the outside covering of the connection cord with the cord clamp. (If the insulator is chafed, electric leakage may occur.)
 - Always connect the ground wire.

(1) Remove the control box metal-B from the control box metal Assy.

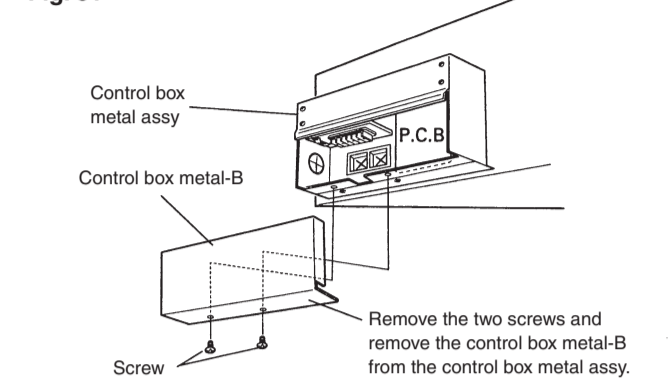

- Connection cord and remote controller cord connections.
 - Clamp the connection cord with the cable clamp and the remote controller cord with the nylon clamp.
 - Connect the connection cord to the terminals with the white characters on the terminal nameplate.
 - Connect the remote controller cord to the terminals with the black characters on the terminal nameplate.

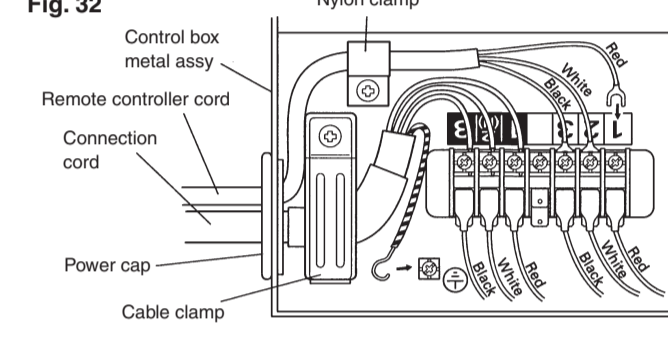

(3) Control box metal-B installation
Fasten control box metal-B with the two screws.
For the connection cord outlet port see Fig. 33.

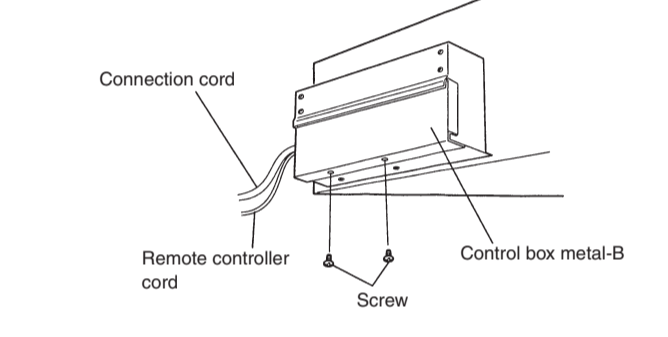

2. OUTDOOR UNIT SIDE

- WARNING**
- Before starting work, check that power is not being supplied to the indoor unit and outdoor unit.
 - Match the terminal board numbers and connection cord colors with those of the indoor unit side. Erroneous wiring may cause burning of the electric parts.
 - Connect the connection cords and the power supply cord firmly to the terminal board. Imperfect installation may cause a fire.
 - Always fasten the outside covering of the connection cord with the cord clamp. (If the insulator is chafed, electric leakage may occur.)
 - Always connect the ground wire.

(1) Remove the terminal cover of the outdoor unit, and insert the end of the connection cord and the power supply cord into the terminal board.

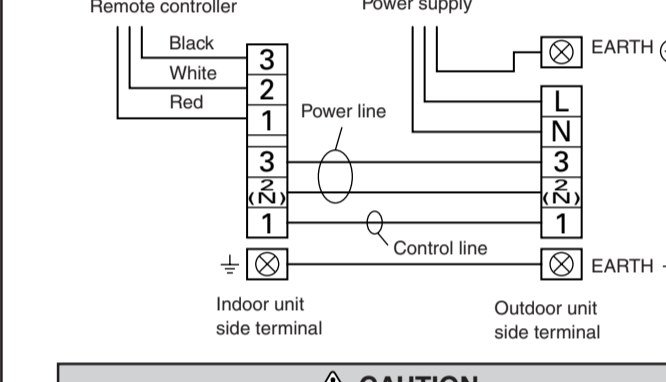
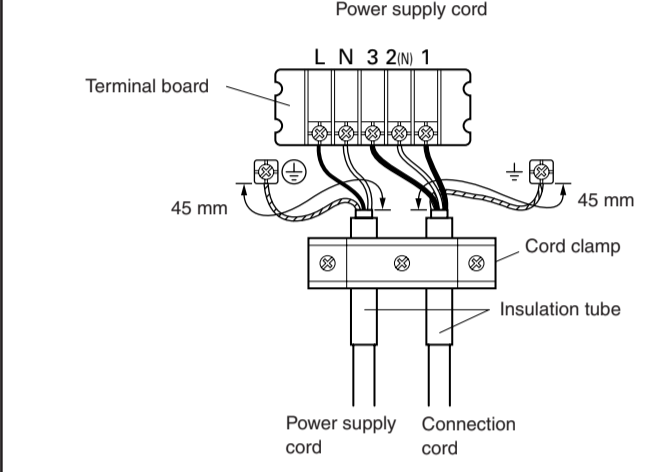
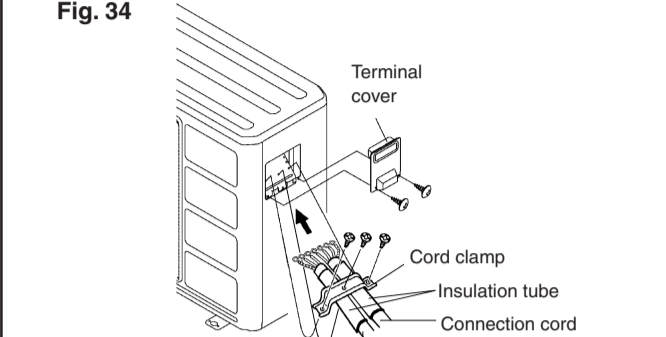

CAUTION
When routing the ground wires, leave slack as shown in the illustrations.

8 POWER

- WARNING**
- The rated voltage of this product is 230 V A.C. 50 Hz.
 - Before turning on the verify that the voltage is within the 198 V to 264 V range.
 - Always use a special branch circuit and install a special receptacle to supply power to the air conditioner.
 - Use a special branch circuit breaker and receptacle matched to the capacity of the air conditioner. (Fuse/Breaker capacity: 30 A)
 - The special branch circuit breaker is installed in the permanent wiring. Always use a circuit that can trip all the poles of the wiring and has an isolation distance of at least 3 mm between the contacts of each pole.
 - Perform wiring work in accordance with standards so that the air conditioner can be operated safely and positively.
 - Install a leakage special branch circuit breaker in accordance with the related laws and regulations and electric company standards.

CAUTION

- The power source capacity must be the sum of the air conditioner current and the current of other electrical appliances. When the current contracted capacity is insufficient, change the contracted capacity.
- When the voltage is low and the air conditioner is difficult to start, contact the power company the voltage raised.
- This air conditioner must be connected to a power source that has an electrical impedance of 0.159 Ω or less or has a supply current of 100 A or greater. If the power supply does not meet the specifications, contact the power company.

CAUTION

- In order to detect the room temperature correctly when using the temperature sensor of the remote controller, do not install the remote controller in a place where it will be exposed to direct sunlight or directly below the air outlet of the indoor unit.
- When installing the remote controller and cord near a source of electromagnetic waves, separate the remote controller from the source of the electromagnetic waves and use shielded cord.
- Do not touch the remote controller PC board and PC board parts directly with your hands.

9 REMOTE CONTROLLER SETTING

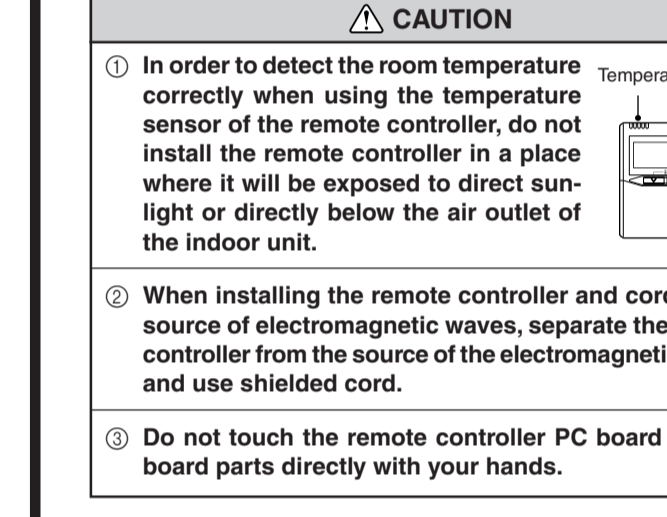

1. INSTALLING THE REMOTE CONTROLLER

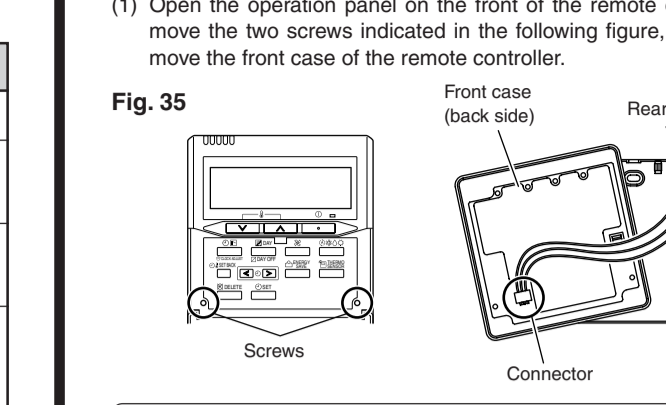

When installing the remote controller, remove the connector from the front case. The wires may break if the connector is not removed and the front case hangs down.
When installing the front case, connect the connector to the front case.

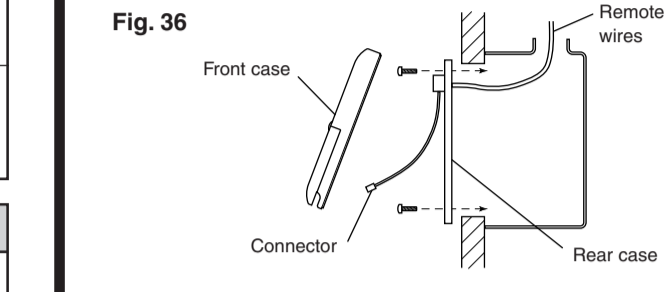

(1) Install the remote controller wires to the terminals on the top of the rear case as shown in the following figure.
(2) Fasten the wires with the binder.
(3) If the remote controller wires run through the room, use a tool to cut away the thin area on the upper center of the front case.

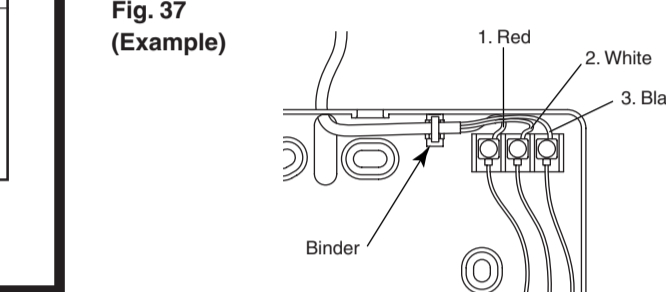

2. ROUTING THE REMOTE CONTROLLER WIRES

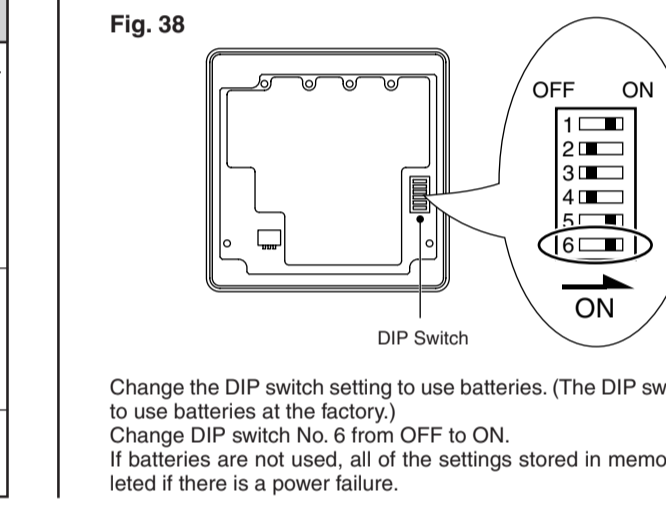

4. SETTING THE ROOM TEMPERATURE DETECTION LOCATION

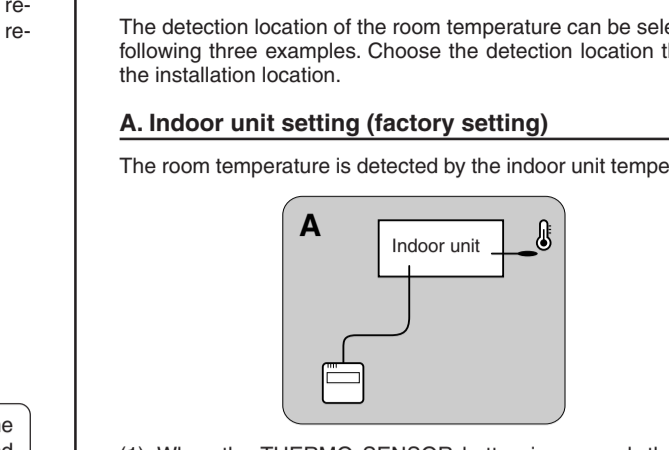

The detection location of the room temperature can be selected from the following three examples. Choose the detection location that is best for the installation location.

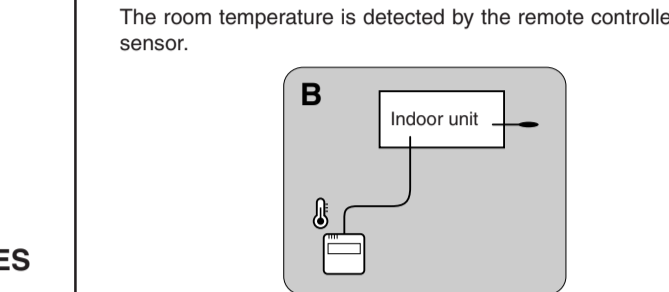

(1) Press the THERMO SENSOR button for 5 seconds or more to unlock the function. The thermo sensor display flashes and then disappears when the function is unlocked.
(2) Press the THERMO SENSOR button. The thermo sensor display appears.
(3) Press the THERMO SENSOR button again for 5 seconds or more to lock the function. The thermo sensor display flashes and then remains on when the function is locked.

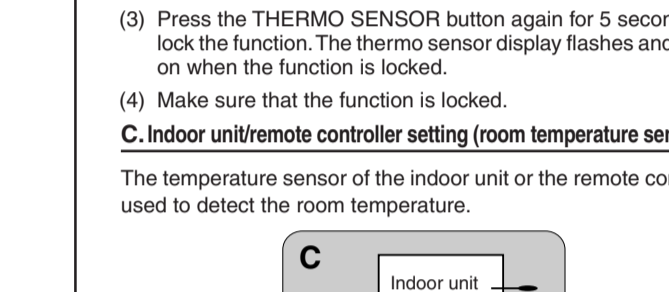

NOTES
If the function to change the temperature sensor is used as shown in examples A and B (other than example C), be sure to lock the detection location. If the function is locked, the lock display will flash when the THERMO SENSOR button is pressed.

10 TEST RUN

CAUTION
Supply power to the crankcase heater for at least 12 hours before the start of operation in winter.

- Stop the air conditioner operation.
- Press the master control button and the fan control button simultaneously for 2 seconds or more to start the test run.

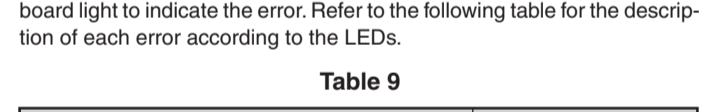

(3) Press the start/stop button to stop the test run.

[SELF-DIAGNOSIS]

When the error indication "E.EE" is displayed, follow the following items to perform the self-diagnosis. "E.EE" indicates an error has occurred.

Error code	Error contents
11	Model abnormal
12	Indoor fan abnormal
13	Outdoor signal abnormal
14	Outdoor EEPROM abnormal

2. OUTDOOR UNIT LEDs

Heat & Cool model (reverse cycle) only
When a malfunction occurs in the outdoor unit, the LEDs on the circuit board light to indicate the error. Refer to the following table for the description of each error according to the LEDs.

Error display	LED1	LED2	Error contents
ON	ON	ON	Model abnormal or EEPROM abnormal
1 quick flash repeated	ON	OFF	Power source connection error
2 quick flash repeated	ON	OFF	Discharge temperature sensor error
3 quick flash repeated	ON	OFF	Outdoor heat exchanger temperature sensor error
4 quick flash repeated	ON	OFF	Outdoor temperature sensor error
5 quick flash repeated	ON	OFF	Communication signal error
6 quick flash repeated	ON	OFF	Indoor unit error
7 quick flash repeated	ON	OFF	Discharge temperature abnormal
8 quick flash repeated	ON	OFF	High pressure abnormal

When the fault is cleared, the LED lamp goes off. However, for discharge pipe temperature abnormal and high pressure abnormal, the LED lamp lights continuously for 24 hours, as long as the power is not turned off.

Error code	Error contents
00	Communication error (indoor unit ↔ remote controller)
01	Communication error (indoor unit ↔ outdoor unit)
02	Room temperature sensor open
03	Room temperature sensor short-circuited
04	Indoor heat exchanger temperature sensor open
05	Indoor heat exchanger temperature sensor short-circuited
06	Outdoor heat exchanger temperature sensor open
07	Outdoor heat exchanger temperature sensor short-circuited
08	Power source connection error
09	Floater switch operated
0A	Outdoor temperature sensor open
0b	Outdoor temperature sensor short-circuited
0c	Discharge pipe temperature sensor open
0d	Discharge pipe temperature sensor short-circuited
0E	Outdoor high pressure abnormal
0F	Discharge pipe temperature abnormal

11 SPECIAL INSTALLATION METHODS

CAUTION
When setting the rotary switch and DIP switches, do not touch any other parts on the circuit board directly with your bare hands.
Be sure to turn off the main power.

1. GROUP CONTROL SYSTEM

A number of indoor units can be operated at the same time using a single remote controller.

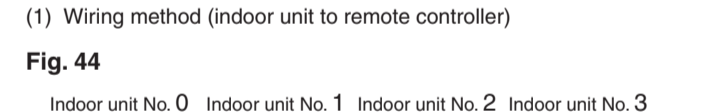

(1) Rotary switch setting (indoor unit)
Set the unit number of each indoor unit using the rotary switch on the indoor unit circuit board.
The rotary switch is normally set to 0.

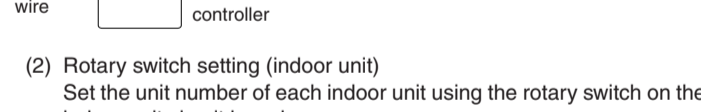

(2) DIP switch setting (remote controller)
Change DIP switch No. 3 on the remote controller from OFF to ON.

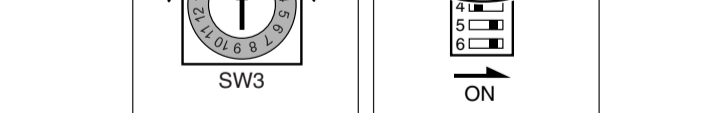

2. DUAL REMOTE CONTROLLERS (OPTIONAL)

Two separate remote controllers can be used to operate the indoor units.

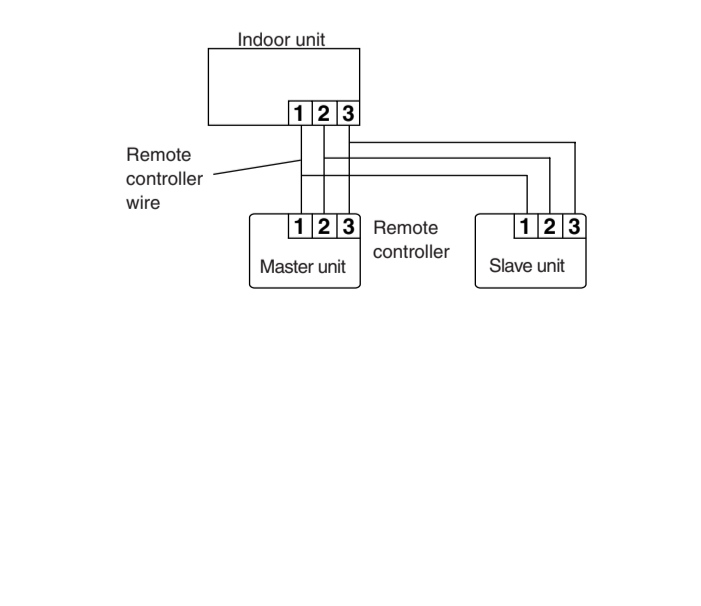

(2) DIP switch setting (remote controller)
Set the remote controller DIP switch Nos. 1 and 2 according to the following table.

Number of remote controllers	DIP-SW No. 1	DIP-SW No. 2	Master unit
1 (Normal)	ON	OFF	
2 (Dual)	OFF	OFF	

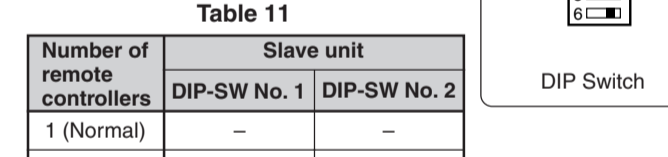

3. CANCELING AUTO RESTART

The auto restart function can be canceled.
(1) DIP switch setting (indoor unit)
Change the DIP switch (SW2) on the indoor unit circuit board from OFF to ON. The auto restart function will be canceled.

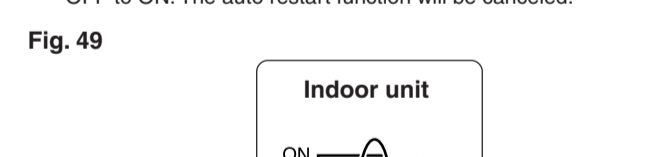

[DIP-SWITCH SETTING]

● Indoor unit

NO.	SW state	Detail
1	OFF	Remote sensor setting
2	Edge *	Control input setting
3	Validity *	Auto restart setting

● Remote controller

NO.	SW state	Detail
1	OFF	Dual remote controller setting
2	*	Group control setting
3	One unit *	Model setting
4	Heat & Cool model *	Auto changeover setting
5	Invalidity *	Memory backup setting
6	Validity *	Memory backup setting

*: Factory setting

12 STATIC PRESSURE CHARACTERISTIC

FAN PERFORMANCE AND AIR FLOW EXTERNAL STATIC PRESSURE (Voltage: 230 V)

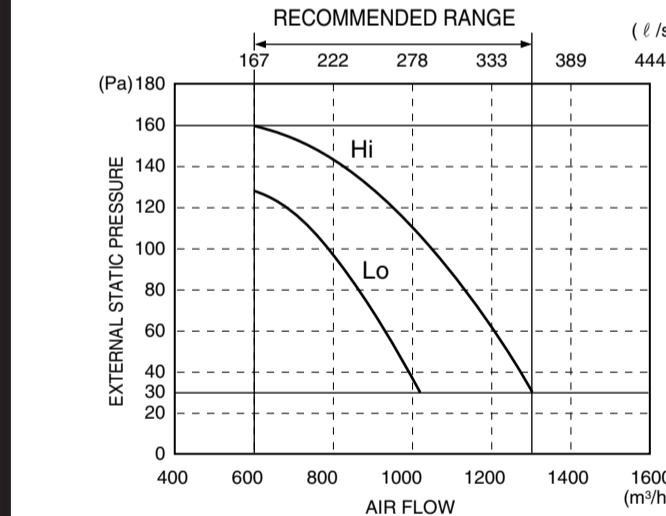

13 OUTLET DUCT CONNECTION

1. DUCT INSTALLATION PATTERN (■ CUT PART)



2. WHEN USING AS A SQUARE DUCT

(1) Cut the slit seam with a cutter.

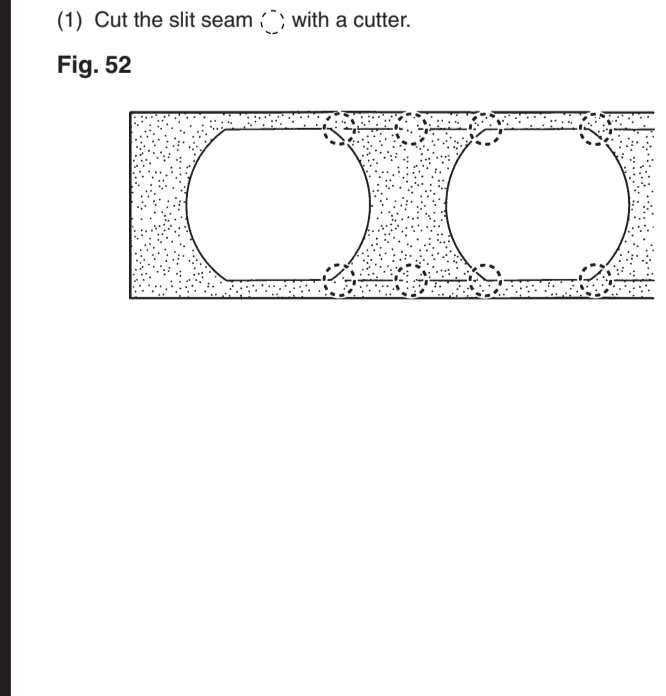

14 INTAKE PORT REAR COVER DIMENSIONS

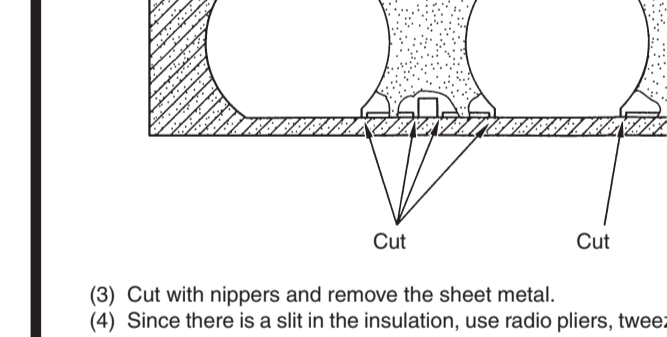
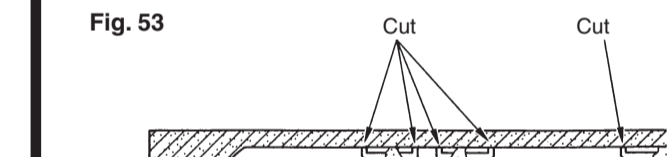

3. SPECIAL ITEMS

When connecting the square duct and round duct, use the optional square flange or round flange and flexible duct.

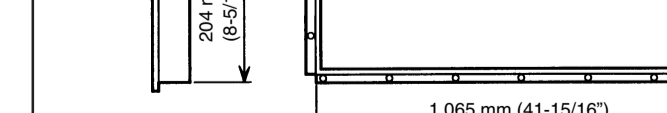
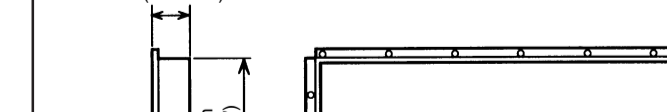
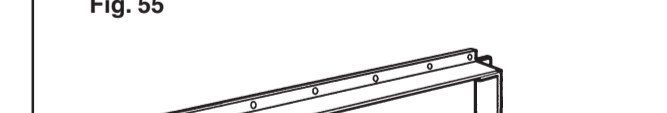
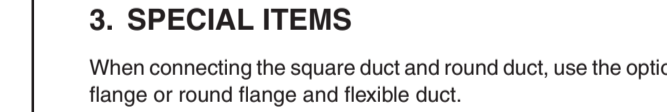
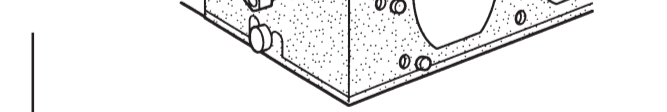

15 INTAKE PORT

(1) The square flange (rear side) and panel (intake panel) are installed at the factory at the places shown in Fig. 57.
(2) When taking in air from the bottom side, reinstall the square flange (rear side) and panel (intake panel).

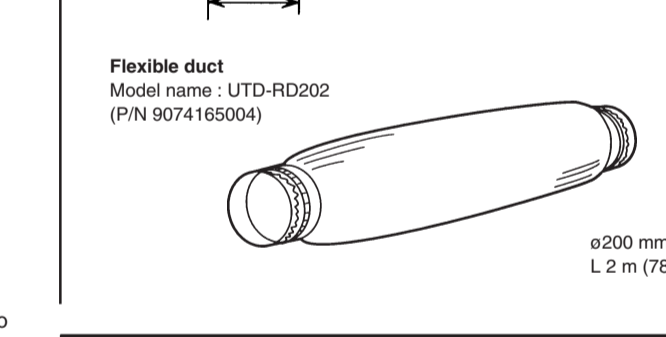

CAUTION

When air is taken in from the bottom side, the operating sound of the product will easily enter the room. Install the product and intake grilles where the effect of the operating sound is small.

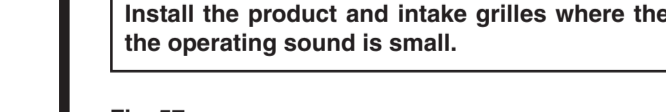
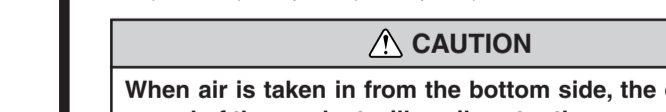
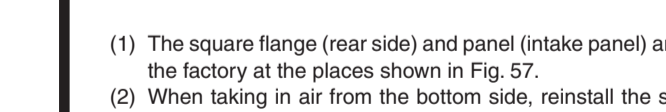
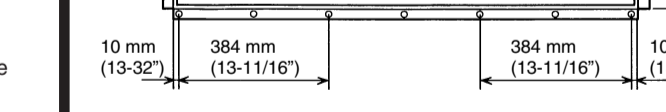
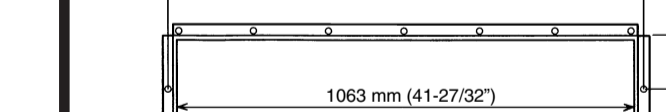

16 FRESH AIR INTAKE (Processing before use)

(1) When taking in fresh air, cut a slit shaped cabinet in the left side of the outer case as shown in Fig. 58 with nippers.
(2) Install the round flange (option parts) to the fresh air intake.

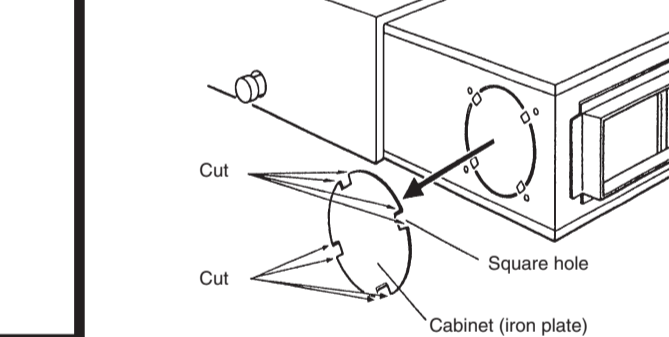

CAUTION

When removing the cabinet (iron plate), be careful not to damage the indoor unit internal parts and surrounding area (outer case).
When processing the cabinet (iron plate), be careful not to injure yourself with burrs, etc.

